



BULLET 3.0

OVERVIEW

STANDARD PARTS

OPTION PARTS

BODYSHELLS

WHEELS/TIRES

DOWNLOADS

VIDEOS

NEWS

PREPARE YOURSELF FOR THE MIGHT OF THE BULLET MT 3.0!

The massively popular HPI Bullet MT 3.0 has been updated with an all-new look, and this super tough off-road fun machine is ready for action at your command!

The Bullet MT 3.0 can blast through any type of terrain thanks to the immense power of its HPI Nitro Star G3.0 engine and a durable 4WD drivetrain. Getting to awesome speeds and catching massive air has never been more fun! The durable, robust design of the Bullet means it can take hard landings and rough action so you can enjoy big air, hard-hitting action whenever and wherever you want!

Undereath the brand new paint scheme, the Bullet 3.0 trucks have a rugged 8-shock double-wishbone suspension, tough shaft drive, metal gear diffs and reliable 2.4GHz radio system. All you need to provide is fuel for the engine and nerves of steel to control the powerful Bullet 3.0!



HPI Racing Bullet NITRO & FLUX Action



BULLET 3.0

BULLET 3.0



With a tall pick-up body and tractor tread tires, the Bullet MT has the classic monster truck style you're looking for! The all-new glossy black finish is offset with silver and orange racing stripes and multi-hole black chrome wheels for an awesome custom look that can't be beat! The wide front grille is coupled with a huge hood scoop, and the extra driving lights add to the aggressive big-truck looks. A sleek roll bar sits over the bed behind the cabin and the window details include roll bars and window nets to finish off the monster truck looks. With the low-profile tractor style tires wrapped around extra-cool black chrome wheels, the Bullet MT has fantastic styling that will be the envy of all your friends!



2.4GHZ RADIO SYSTEM

All HPI kits are fitted with a comfortable and feature-packed HPI 2.4GHz radio system for supreme control and confidence! The radio features a pistol-grip design with a realistic steering wheel, servo reversing and steering dual rate. It's also extremely lightweight due to it requiring only four AA batteries. You won't have to worry about radio crystals or what channel other RC racers are using with our 2.4GHz technology - the radio does all that work for you! The radio prevents frequency conflicts automatically and changes channels if there is any interference. Finally, if you ever lose radio signal, an **electronic failsafe** will bring it to a safe and controlled stop. You'll have professional-level control in one easy RTR package!

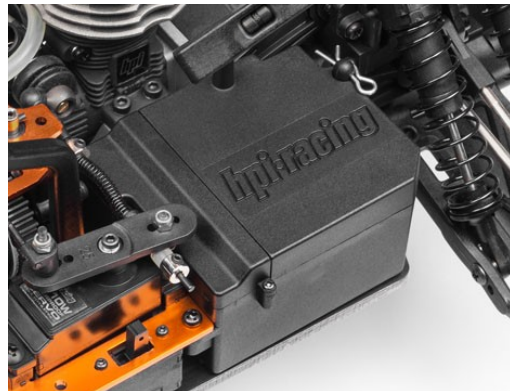

PROTECTED ELECTRONICS

The Bullet 3.0 trucks feature a protected receiver compartment for the truck's battery pack and receiver, plus **waterproof steering and throttle servos** that allow you to keep running your Bullet in extreme conditions that would kill just about any other vehicle! Want to tackle that muddy bog? How about that stream crossing? A bit of rain about to fall? It's all good for the Bullet trucks! Please note: This HPI vehicle is designed to provide water protection so it can be driven in wet conditions (e.g. rain, snow, puddles). Not for submersion. See manual for details.

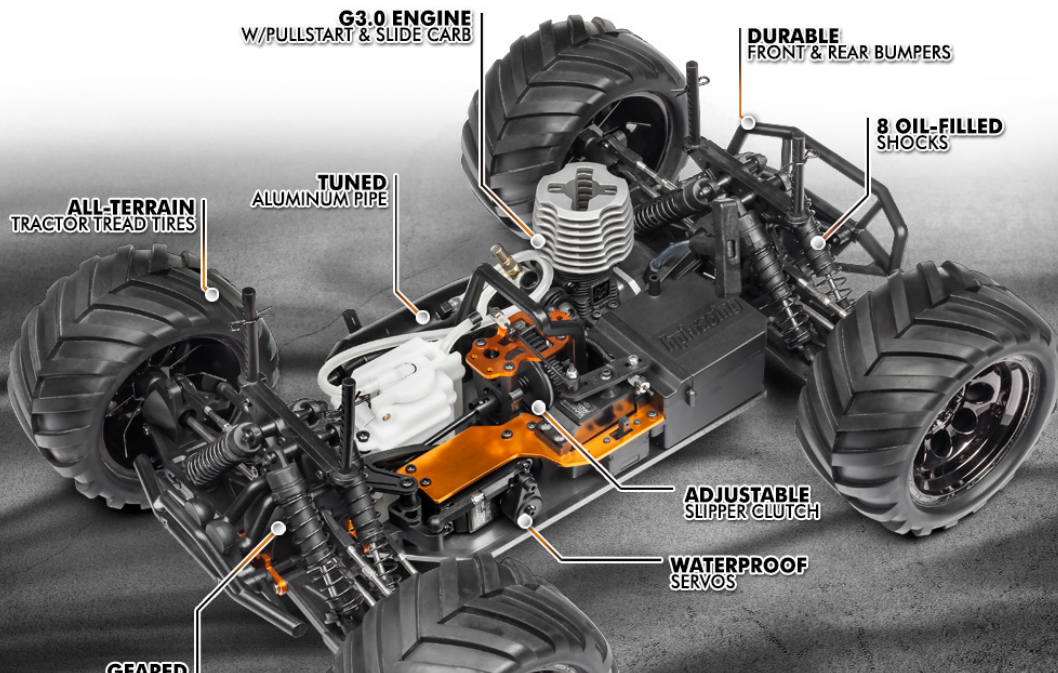

FRONT & REAR DIFFS

BLACK CHROME
PAINTED WHEELS

CHASSIS



STRONG ALUMINUM ALLOY CHASSIS

Formed from **6061 aluminum** for a combination of strength and light weight, the Bullet 3.0 chassis is durable and looks great! Thick sheet aluminum is stamped into shape to form the ideal backbone for all the various components that make the Bullet trucks so tough! The front kick-up provides extra control at all speeds, essential for a **go-anywhere, do-anything** vehicle like the Bullet. The sides are also bent upwards to give extra ground clearance in tight turns, but also vastly increased longitudinal stiffness - perfect for all your off-road adventures!

COMPACT & BALANCED LAYOUT

The Bullet 3.0 is packed with features, with every component placed exactly where it needs to be to operate in the most efficient way possible. The steering servo is placed in a "laydown" configuration for a low center of gravity, and the weight of the engine fuel tank balances the electronics on the other side of the chassis. Derived from decades of HPI Racing experience, the Bullet takes advantage of our design team's knowledge to give you a perfectly balanced, compact and easily maintained nitro monster truck!

BULLET 3.0

DRIVETRAIN

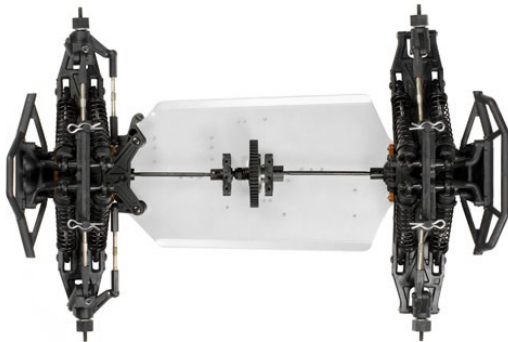

TOUGH 4WD SHAFT DRIVETRAIN

The drivetrain used in all Bullet trucks is a **full-time four-wheel drive shaft-type drivetrain**, just like the one used in 1/8th scale buggies like the World Champion HB D815 buggy. A shaft drivetrain is the best option for a kit that's expected to encounter every possible driving condition and track surface, so whether you're blasting through mud, dirt, grass, snow or gravel, it's the ideal type of drivetrain for your off-road adventures!

NITRO-POWERED FUN

A strong plastic spur gear takes the power from the engine and transmits it front and rear through an **adjustable dual pad slipper clutch**. The center dogbones drive the front and rear bevel differentials, which use **4 internal gears** for increased durability and lifetime over weaker 2-gear diffs. Braking power is provided by the adjustable steel disc brake for maximum stopping strength to all four tires!



STEEL DOGBONES

EFFICIENT BALL BEARINGS

Extra-tough hardware is a major feature of the Bullet trucks, and it's no different when you look at the driveshafts. Super strong coated steel dogbones transfer the power from the front and rear differentials into the wheels. On each axle is a standard-size 14mm hex adapters using nylon, and a sturdy steel locknut holds the wheels on place on each axle.

For extra efficiency, all the components of the drivetrain, from the spur gear to the wheel axles, spin on long-life, rubber-sealed **ball bearings**. With these bearings you get long runtimes and long engine life while the rubber seals keep out dust and grime!

BULLET 3.0

SUSPENSION AND STEERING



RUGGED LONG SUSPENSION ARMS

Extra-long suspension arms provide stability, and thick suspension pins give you extra insurance against crash damage. The suspension arms feature a solid construction for extra-tough construction and extreme durability. Multiple shock mounting locations let you fine-tune the handling for whatever you plan to be doing. Go ahead and try it - even though it's perfectly set at the factory for neutral handling, we don't mind if you try something new!

DOUBLE SHOCKS AT EACH CORNER

8 extra-long shock absorbers control the damping on the Bullet 3.0, and are precisely filled with oil for exceptional handling in turns and cushioning when landing big jumps. With big coil-over springs they are the perfect match to the long suspension arms! The shocks are customizable with HPI oils and springs, as well as different shock mount locations.



FLEXIBLE PLASTIC PARTS

Tough nylon suspension parts include the hubs, steering knuckles, and rear uprights, which are designed to endure any sort of punishment. The front hubs have an oversized rock guard to keep pebbles and stones away from the dogbone/axle joint. Optional shock mounting points are provided on the suspension arms for lowering the stance of the truck slightly (great for running on-road) and stiffening up the suspension at the same time, without using option parts.

WATERPROOF STEERING & THROTTLE SERVOS

The **waterproof HPI SF-10W servo** pulls double duty on the Bullet 3.0, with one SF-10W easily handling the steering of the front wheels and another SF-10W controlling the carburetor and brake positions. The HPI SF-10W servo is a powerful and reliable unit, and thanks to a strong spring-loaded servo saver it can take the hits of jumps and crashes as you drive all day long. It's also completely waterproof so it can take the abuse of all-terrain truck action!



ADJUSTABLE STEEL TURNBUCKLES

Strong steel turnbuckles link connects the servo to the steering hubs through a reliable bellcrank steering system. The turnbuckles are light yet strong, and allow you to tune the Bullet with different toe settings. For advanced tuning, turnbuckle links let you make quick adjustments, and even the steering links use turnbuckles so you can change the front toe setting if you wanted.

RUGGED ALL-TERRAIN TIRES

The extra cool-looking all-terrain tires will provide an amazing amount of grip on loose or hard-packed dirt, grass, mud and more. The sturdy tractor-tread tires are perfect for loose dirt, wet mud and work great even on dry tarmac, so you can hit any driving surface with confidence and assurance. The tires are securely glued to black chrome coated wheels for extra style points!

BULLET 3.0

G3.0 ENGINE WITH PULLSTART & SLIDE CARB

HPI NITRO STAR POWER!

The Nitro Star G3.0 engine provides all the muscle for the Bullet 3.0 nitro trucks - it's loud, powerful and strong, to give you amazing acceleration and awesome top speed! The engine is started by a simple pullstarter system and is protected by a unique splash cover and 2-stage air filter for extra protection. The two-needle carburetor allows you to fine-tune the performance of the engine for any conditions. With nitro power at your fingertip, you can have fun all day long, only stopping to refuel!

Nitro Star G3.0 specifications

- Displacement: 3.01cc (0.18 cubic inch)
- Bore: 16.8mm
- Stroke: 13.6mm
- Power: 2.2hp @ 31,000 RPM
- Maximum RPM: 32,000 RPM
- Carburetor: F2-6.5 (Composite 6.5mm), slide-type with twin needle adjustments
- ABC components: aluminium piston with chrome-plated brass sleeve or cylinder
- 2-piece racing clutch
- 75cc fuel tank
- Aluminium heat sink
- Dual-element oiled foam air filter with rain cover

**BULLET 3.0** FEATURES

FEATURES

- Factory-assembled & pre-painted nitro-powered 4WD Monster Truck
- 2.4 GHz radio system for crystal-free, comfortable control
- Protected receiver/battery box
- Strong and reliable Nitro Star G3.0 engine
- Easy and simple pullstarter for instant action
- Big 75cc fuel tank gives you plenty of runtime



- Waterproof steering & throttle servos
- Painted and detailed bodysell with all-new paint and decal design
- 6061 aluminum chassis provides the ideal backbone
- Tough bumpers combine with skid plates to protect all 4 corners
- 8 oil-filled shocks provide a plush ride
- Extra-long suspension arms provide stability and balance
- Proven racing design throughout
- Steel turnbuckle links allow you to custom-tune the ride
- Sealed shaft drivetrain is maintenance-free and super strong
- Double-pad slipper clutch design for extra drivetrain protection
- All-terrain tires look fantastic on black chrome wheels
- A smart metal washer prevents over-tightening of wheel nuts
- Additional track-tuning options included in the kit!



#110661 RTR BULLET MT 3.0 W/ 2.4GHZ

1/10th Scale 4WD Electric Monster Truck with Nitro Star G3.0 engine, 2.4GHz Radio System and Painted Monster Truck Body

SPECIFICATIONS:

Length: 417mm
 Width: 336mm
 Height: 160mm (Adjustable)
 Wheelbase: 272mm
 Track: 263mm
 Drivetrain: Shaft 4WD

WHAT YOU NEED:

Nitro Car Fuel - **HPI Power Fuel** recommended!
 Fuel Bottle - **#74115 500cc Fuel Bottle** recommended!
 Glow Plug Igniter

Includes: 4 AA batteries for transmitter and 4 AA batteries for receiver pack

Specification may be subject to change



Copyright 1986-2019 HPI Racing Ltd.
 All rights reserved. Images may not be used without express permission.

