

DA **Monteringsvejledning**

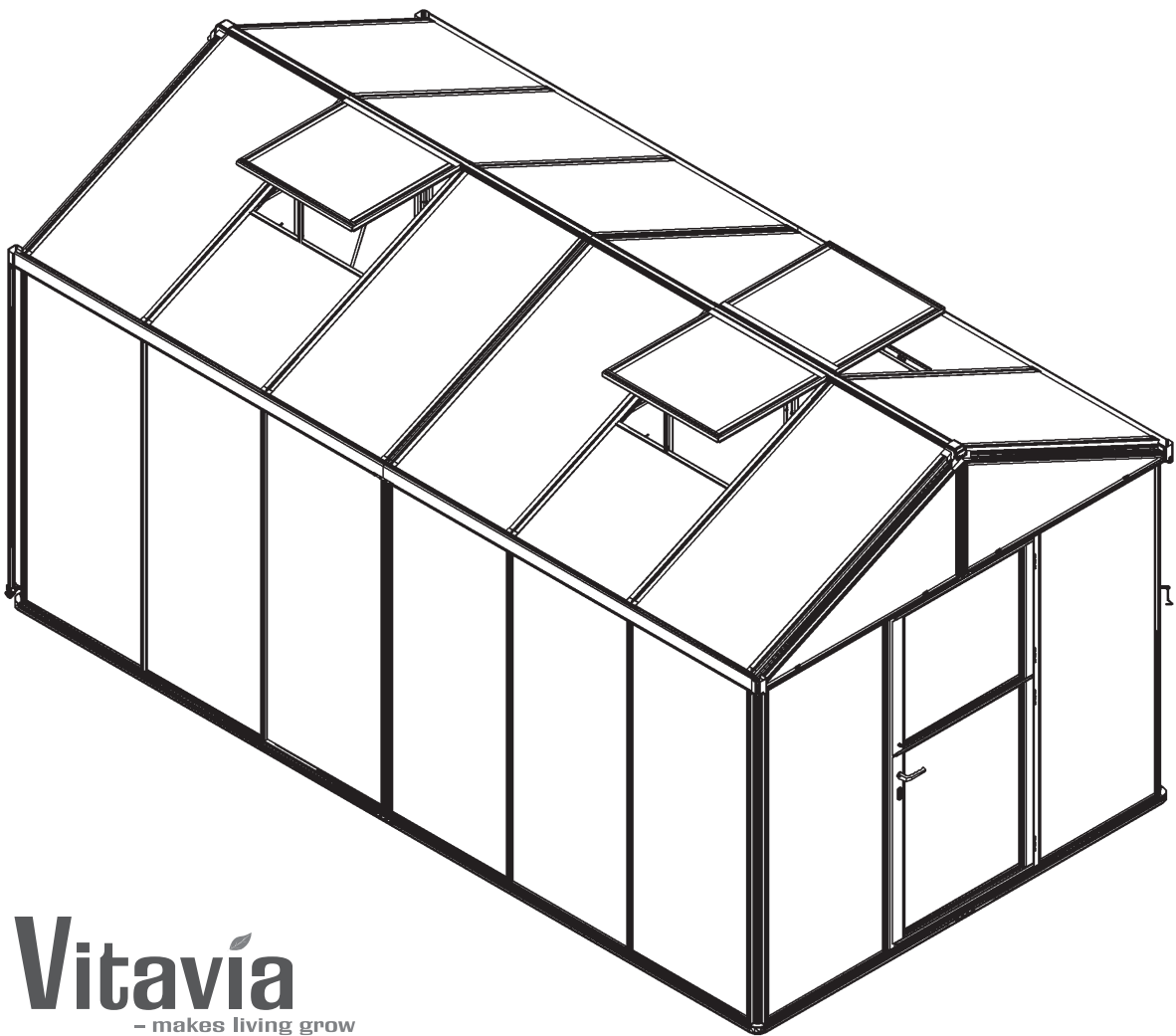

Vitavia
- makes living grow

ZEUS 2
8100, 10000, 11900, 13800, 15700

Kære kunde,

Tak fordi De har valgt et Vitavia produkt. Vi er overbevist om, at De vil få megen glæde af og mange gode stunder i Deres drivhus.



Læs venligst hele denne monteringsvejledning, inden samling og opstilling af drivhuset påbegyndes.

• Indhold / symboler	S. 2
• Anbefalinger / gode råd	S. 3
• Sikkerhedshenvisninger	S. 4
• Vedligeholdelse og pleje	S. 5
• Stykliste oversigt	S. 6
• Stykliste pakke 1/1	S. 7-19
• Stykliste pakke 1/2	S. 20
• Stykliste pakke 2	S. 21-25
• Stykliste pakke 3	S. 26-30
• Stykliste pakke 4	S. 31-35
• Stykliste pakke 5 - ventilationsvinduer	S. 36-37
• Fundament / sokkel	S. 38-39
Samling og montering	
• Trin 1 Bundramme og hjørnestolper	S. 40-41
• Trin 2 Midterprofil og tagrem	S. 42-43
• Trin 3 Mellemprofiler	S. 44-45
• Trin 4 Tag	S. 46-49
• Trin 5 Ventilationsvinduer	S. 50-51
• Trin 6 Dør	S. 52-55
• Trin 7 Isætning af glas / polycarbonatplader	S. 56-65
• Trin 8 Færdiggørelse	S. 66-67
• Trin 9 Nedløbsrør	S. 68-69



Tegninger med enkelramme er set indefra.

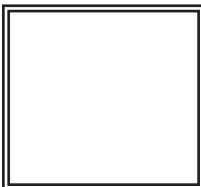

Tegninger med dobbelramme er set udefra.



**NB!: Vigtigt tip!
Bemærk venligst!**

Bemærk: Vi anvender betegnelsen ”kode” som synonym for ”artikelnummer” eller ”del nr.”
Kodenumre er angivet som et 4-cifret tal umiddelbart efter navnet på delen.
Henvisninger til tabeller og illustrationer er anført som tal indføjet i parenteser.



De bør altid bruge handsker, når De arbejder med polycarbonatplader eller glas. Skarpe kanter kan forårsage skader. Der kan også forekomme skarpe kanter på kanter og hjørner på aluminiumsprofiler. Her bør De også bære handsker. Ved isætning af glas bør De også anvende beskyttelsesbriller, sikkerhedssko og hovedbeskyttelse (sikkerhedshjelm). Itugået glas udgør en sikkerhedsrisiko og bør bortskaffes med forsigtighed.

Bemærk venligst!

Dette produkt er konstrueret som et drivhus beregnet til planteavl og er som sådan ikke konstrueret til at være helt tæt, da det er nødvendigt med udluftning bl.a. for at undgå kondensdannelse.

Såfremt De ønsker at anvende drivhuset som et ”uderum/stue” eller lignende, gør vi udtrykkeligt opmærksom på, at drivhuset ikke er 100 % vandtæt, og at vi ikke påtager os noget ansvar for eventuelle skader på løsøre el. lign., der er anbragt i drivhuset.

Til montage af dette produkt kræves min. 2 personer.

Skulle De få problemer med drivhusmontagen eller glasisætning, bedes De kontakte Deres forhandler eller vor kundeservice på opj@opj.dk

Anvend ikke vold.

Placering

Vælg et solrigt sted, hvor der er mest muligt læ. Undgå at placere drivhuset på steder, hvor der kan opstå turbulens pga. nærtstående bygninger.

Vigtigt

Før De begynder at samle Deres drivhus, kontroller venligst efter indholdsfortegnelsen, at alle dele er medleveret. Tag de enkelte bundter ud af kassen for bedre at kunne kontrollere indholdet. Undgå så vidt muligt at åbne delpakkerne, før De når til det pågældende punkt i vejledningen.

Numrene på bundterne stemmer overens med nummereringen i monteringsvejledningen.

Det er vigtigt ikke at blande åbnede bundter.

Hvis der mangler noget, kontakt venligst Deres forhandler.

Såfremt De mener, at en del ikke passer, må De under ingen omstændigheder begynde at tilpasse denne del ved at bore eller save i aluminiumsprofilerne. Kontakt i stedet vor kundeservice på opj@opj.dk, der vil hjælpe Dem videre.

Vi forbeholder os ret til at foretage tekniske ændringer af produktet og dets specifikationer, hvilket kan medføre ændringer i vejledningerne.

På vor hjemmeside vil De altid kunne finde den nyeste udgave af monteringsvejledningen. Såfremt denne måtte afvige væsentligt fra Deres produkt, er De velkommen til at kontakte vor kundeservice på opj@opj.dk. De kan identificere Deres udgave af vejledningen ved hjælp af det nummer, der er anført nederst på alle sider i vejledningen.

Nødvendigt værktøj (indgår ikke i leverancen):

Skruetrækker (stjerne PH2 og PZ2), Akku-boremaskine med moment, 1x10 mm fastnøgle, 1x10 mm gaffelnøgle, 1-2 trappestiger 1,80 m, 1 målebånd/tommestok, 1 vaterpas, 1 hobkniv, 1 gummihammer, 1 skævbider

- **De bør altid bruge handsker, når De arbejder med polycarbonatplader eller glas. Skarpe kanter kan forårsage skader. Der kan også forekomme skarpe kanter på kanter og hjørner på aluminiumsprofiler. Her bør De også bære handsker. Ved isætning af glas bør De også anvende beskyttelsesbriller, sikkerhedssko og hovedbeskyttelse (sikkerhedshjelm). Itugået glas udgør en sikkerhedsrisiko og bør bortskaffes med forsigtighed.**
- **NB! Udvis forsigtighed ved glasmontage. Glasset kan splintre under monteringen.**
- **Bær gerne sikkerhedsbriller, medens glasset monteres.**
- **Samling af drivhuset og montering af glas bør ikke foretages i stærk blæst eller storm.**
- **Efter ca. 2 uger efterspændes alle bolte uden at overspænde disse.**



Læs hele monteringsvejledningen, inden samlingen af drivhuset påbegyndes.



Vedligeholdelse

Drivhuset bør lejlighedsvis rengøres grundigt med et mildt rengøringsmiddel. Glas-
set kan rengøres med et hvilket som helst rengøringsmiddel, der ikke skader alumi-
niumsprofiler eller glasholdere og clips, f.eks. Vitavia drivhusrens eller brun sæbe.
Test eventuelt på et mindre område, hvis De er i tvivl.

Dørskinnerne bør regelmæssigt rengøres og smøres med stearin/grafitolie.

Ved snefald fjernes sneen fra taget, således at der ikke opstår risiko for skader som
følge af snebelastningen af glas og profiler. Ved kraftigt snefald og ved skiftevis tø-
og frostvejr skal sne fjernes hurtigst muligt fra taget.

Ved risiko for kraftigt snefald understøttes tagryggen med en stolpe eller lign.

Ved kraftig blæst skal alle vinduer og døre lukkes. Afmonter / deaktiver eventuelle
automatiske vinduesåbnere.



Anmærkning

Vi anbefaler, at De sørger for, at Deres husforsikring også dækker Deres drivhus.
Overhold alle byggevedtægter. Kontakt Teknisk Forvaltning i Deres kommune, hvis
De er i tvivl.

Typebetegnelsen skal De bruge ved bestilling af evt. reservedele, så opbevar ven-
ligst montagevejledningen til senere brug.

Skulle De få problemer med drivhusmontagen eller glasisætning, bedes De kontakte
Deres forhandler eller vor kundeservice på opj@opj.dk

Følg de beskrevne arbejdsgange meget omhyggeligt. Såfremt De mener, at der skul-
le være fejl ved produktet eller i vejledningen, eller hvis noget er uklart, er De vel-
kommen til at kontakte os på opj@opj.dk Vi forsøger løbende at opdatere vore vej-
ledninger og modtager gerne input via e-mail.

Styklister







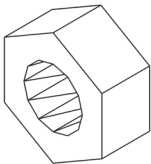
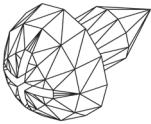
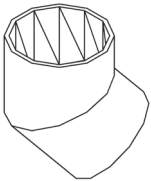
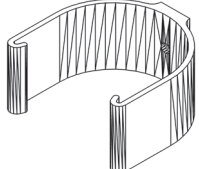

Kontroller først om De har modtaget det korrekte antal delpakker passende til Deres model ved hjælp af nedenstående oversigttabel

Model VM0009-Z2	Pakke 1/1 - 1/6 ZE2	Pakke 1/1 - 2/6 ZE2	Pakke 1/1 - 3/6 ZE2	Pakke 1/1 - 4/6	Pakke 1/1 - 5/6	Pakke 1/1 - 6/6
8100	1x	1x	1x	1x	1x	1x
10000	1x	1x	1x	1x	1x	1x
11900	1x	1x	1x	1x	1x	1x
13800	1x	1x	1x	1x	1x	1x
15700	1x	1x	1x	1x	1x	1x

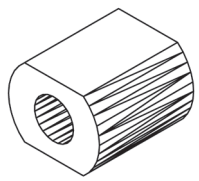
Model VM0009-Z2	Pakke 1/2		Pakke 2		Pakke 3 - 1/2	Pakke 3 - 2/2
8100	1x		2x		-	-
10000	1x		1x		1x	1x
11900	1x		-		2x	2x
13800	2x		-		1x	1x
15700	3x		-		-	-

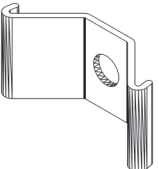

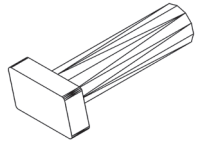
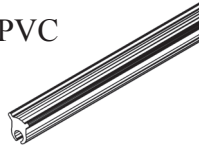

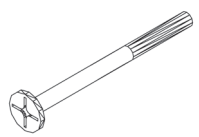
Model VM0009-Z2	Pakke 4 - 1/2	Pakke 4 - 2/2				Pakke 5
8100	-	-				-
10000	-	-				-
11900	-	-				1x
13800	1x	1x				1x
15700	2x	2x				1x

Stykliste

Pakke 1/1 - 1/6 ZE2					Antal stk. / Model					
Kode nr.	Artikel	Montage- trin	Længde i mm	Antal i delpakke	8100	10000	11900	13800	15700	Profil
1002		9	M6	2x	2x	2x	2x	2x	2x	
1006		4b 5 6 9	3.5x6	22x	32x	32x	38x	38x	38x	
1402		9	36	2x	2x	2x	2x	2x	2x	
1403		9	20	2x	2x	2x	2x	2x	2x	
1405		9	15	2x	2x	2x	2x	2x	2x	
1409		9	20	2x	2x	2x	2x	2x	2x	
1412		9	M6x22	2x	2x	2x	2x	2x	2x	
6090	PVC 	7b 7c	56000	1x	77000	85500	94000	103000	112000	
7048		4b	M6x80	2x	0	1x	2x	2x	2x	

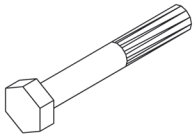
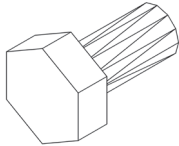
VM0009-Z2

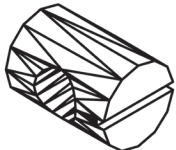
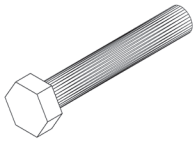
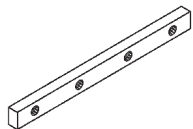
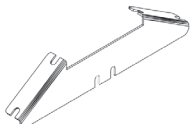

Stykliste

Pakke 1/1 - 1/6 ZE2					Antal stk. / Model					
Kode nr.	Artikel	Montage- trin	Længde i mm	Antal i delpakke	8100	10000	11900	13800	15700	Profil
7050		7b	M6x42	92x	126x	138x	150x	162x	174x	
7052		2, 3 4, 5 6, 7a	M6x12	96x	146x	168x	194x	216x	238x	
7053		1, 2 3, 4 5, 6 7, 8	M6x4	223x	307x	341x	379x	413x	447x	
7054		4b 6	M6x100	8x	12x	12x	14x	14x	14x	
7055		4b 6	M6x10 x14	8x	12x	12x	14x	14x	14x	
7058		7c	M6x38	22x	22x	22x	22x	22x	22x	
7061		1 4a 7a	117	9x	13x	15x	17x	17x	17x	
7062		4	235	4x	6x	7x	8x	9x	10x	
7063		3	255	4x	8x	10x	12x	14x	16x	

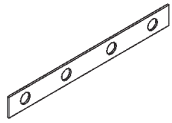
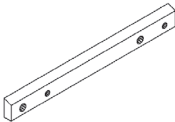
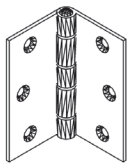
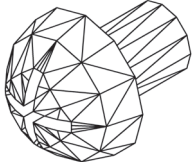
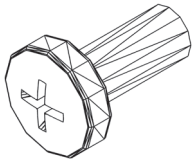
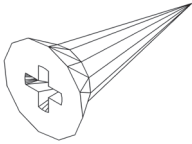
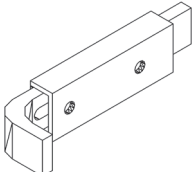
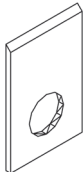
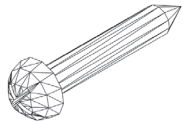

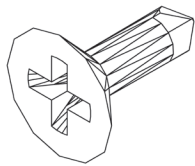
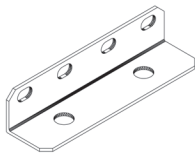

VM0009-Z2

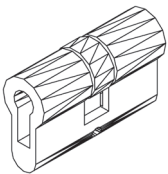
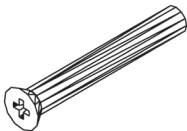
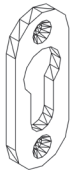
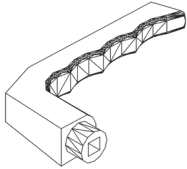
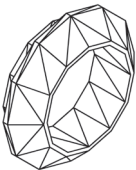
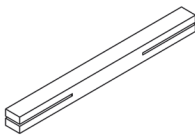
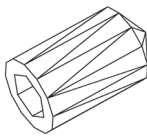
Pakke 1/1 - 1/6 ZE2					Antal stk. / Model					
Kode nr.	Artikel	Montage- trin	Længde i mm	Antal i delpakke	8100	10000	11900	13800	15700	Profil
7064		1 4a 7a	117	1x	5x	5x	5x	5x	5x	
7065		4a	140	2x	2x	2x	2x	2x	2x	
7066		6	75	4x	4x	4x	4x	4x	4x	
7080		1 4a 7a	M6x8	36x	52x	60x	68x	68x	68x	
7081		4a	M5x13	4x	4x	4x	4x	4x	4x	
7082		6b	3.9x13	4x	4x	4x	4x	4x	4x	
7085		6a	95	1x	1x	1x	1x	1x	1x	
7086		6b	23	1x	1x	1x	1x	1x	1x	
7087		6a	5x30	2x	2x	2x	2x	2x	2x	

Styklister

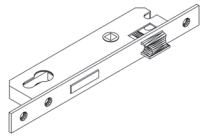
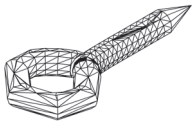
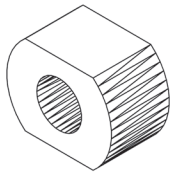
Pakke 1/1 - 1/6 ZE2					Antal stk. / Model					
Kode nr.	Artikel	Montage- trin	Længde i mm	Antal i delpakke	8100	10000	11900	13800	15700	Profil
7088		6 8	3.9x13	32x	30x	30x	30x	30x	30x	
7095		1	117	8x	8x	10x	12x	12x	12x	
7101		6b	62	1x	1x	1x	1x	1x	1x	
7102		6b	M5x35	1x	1x	1x	1x	1x	1x	
7103		6b	65	2x	2x	2x	2x	2x	2x	
7104		6b	125	2x	2x	2x	2x	2x	2x	
7106		6b	Ø 27	2x	2x	2x	2x	2x	2x	
7107		6b	100	1x	1x	1x	1x	1x	1x	
7108		6b	4.7x8	2x	2x	2x	2x	2x	2x	

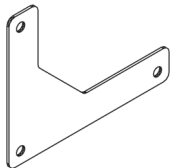
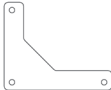
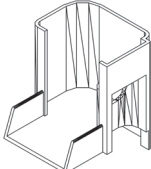
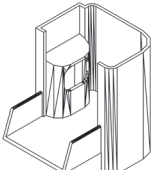
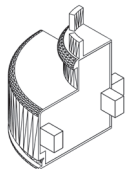
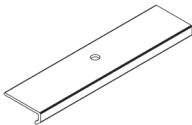



VM0009-Z2

Pakke 1/1 - 1/6 ZE2					Antal stk. / Model					
Kode nr.	Artikel	Montage- trin	Længde i mm	Antal i delpakke	8100	10000	11900	13800	15700	Profil
7109		6b	240	1x	1x	1x	1x	1x	1x	
7111		8	35	1x	1x	1x	1x	1x	1x	
7112		8	8	1x	1x	1x	1x	1x	1x	
7113		8	100	1x	1x	1x	1x	1x	1x	
7114		6	138	4x	4x	4x	4x	4x	4x	
7128		8	71	1x	1x	1x	1x	1x	1x	
7129		8	71	1x	1x	1x	1x	1x	1x	
7200		1	62	4x	4x	4x	4x	4x	4x	
7240		7a	88	2x	2x	2x	2x	2x	2x	



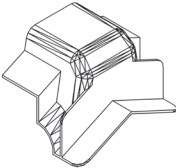
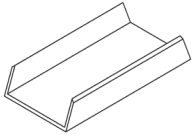

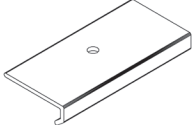
Stykliste

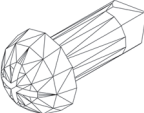
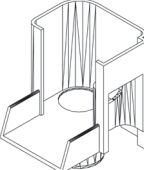
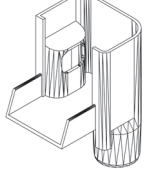
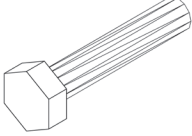
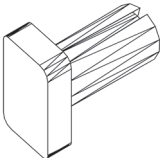
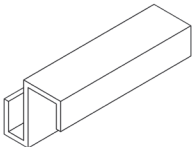
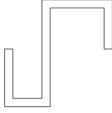
VM0009-Z2

Stykliste

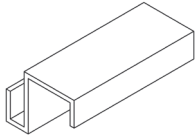
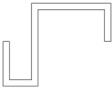
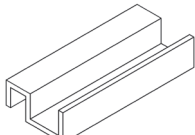
Pakke 1/1 - 1/6 ZE2					Antal stk. / Model					
Kode nr.	Artikel	Montage- trin	Længde i mm	Antal i delpakke	8100	10000	11900	13800	15700	Profil
7266		8	91	2x	2x	2x	2x	2x	2x	
7292		7a	100	2x	2x	2x	2x	2x	2x	
7342		7a	45	4x	4x	4x	4x	4x	4x	
7349		7a* 8	3.9x10	6x	50x	62x	74x	86x	98x	
7370		8	71	1x	1x	1x	1x	1x	1x	
7371		8	71	1x	1x	1x	1x	1x	1x	
7390		2	M6x30	4x	4x	4x	4x	4x	4x	
7399		1 8	M6x12	9x	9x	9x	9x	9x	9x	
7406		7b	30	6x	14x	16x	18x	20x	22x	

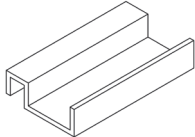







VM0009-Z2

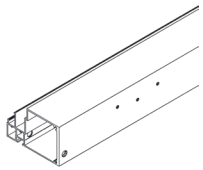
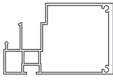
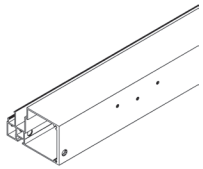
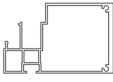
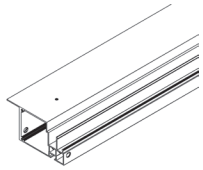
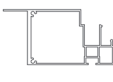
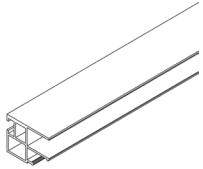

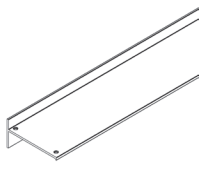
Pakke 1/1 - 1/6 ZE2					Antal stk. / Model					
Kode nr.	Artikel	Montage- trin	Længde i mm	Antal i delpakke	8100	10000	11900	13800	15700	Profil
7407		7b	30	6x	14x	16x	18x	20x	22x	
7408		7b	30	8x	8x	8x	8x	8x	8x	
7409		7b	30	8x	8x	8x	8x	8x	8x	

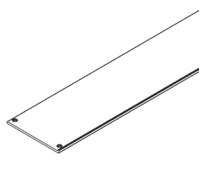
Styklister

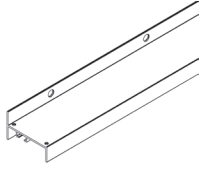
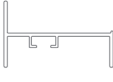
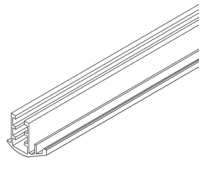
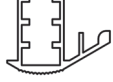
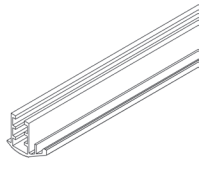
VM0009-Z2

Styklister

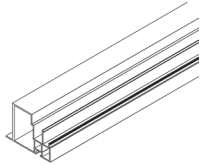
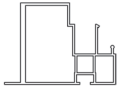
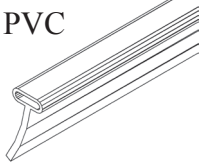

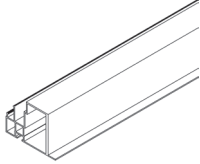
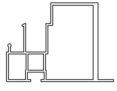
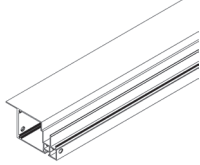
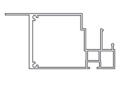



Pakke 1/1 - 2/6 ZE2					Antal stk. / Model					
Kode nr.	Artikel	Montage- trin	Længde i mm	Antal i delpakke	8100	10000	11900	13800	15700	Profil
7015		6b	1000	1x	1x	1x	1x	1x	1x	
7017		6a	717	1x	1x	1x	1x	1x	1x	
7018		6a	717	1x	1x	1x	1x	1x	1x	
7022		6a 6b	708	4x	4x	4x	4x	4x	4x	
7023		6b	850	1x	1x	1x	1x	1x	1x	
7024		6a	850	1x	1x	1x	1x	1x	1x	
7025		6a 6b	850	2x	2x	2x	2x	2x	2x	
7031		7c	996	2x	2x	2x	2x	2x	2x	
7035		7c	713	2x	2x	2x	2x	2x	2x	



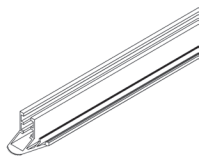
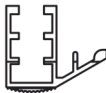
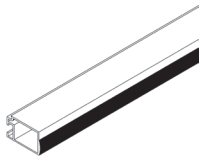
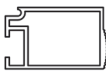
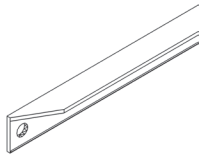

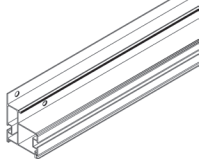
Pakke 1/1 - 2/6 ZE2					Antal stk. / Model					
Kode nr.	Artikel	Montage- trin	Længde i mm	Antal i delpakke	8100	10000	11900	13800	15700	Profil
7045		2	1775	1x	1x	1x	1x	1x	1x	
7083	PVC 	6a 6b	900	2x	2x	2x	2x	2x	2x	
7115		2	1775	1x	1x	1x	1x	1x	1x	
7116		6b	1000	1x	1x	1x	1x	1x	1x	

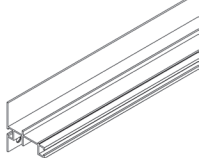
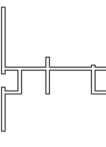
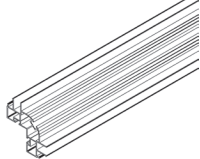
Styklister

VM0009-Z2

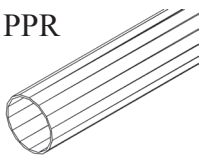
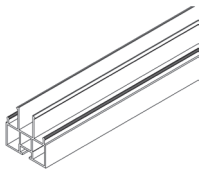
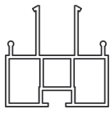
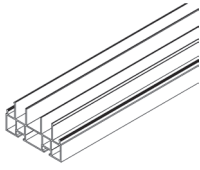
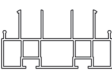
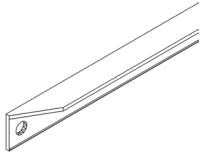
Stykliste

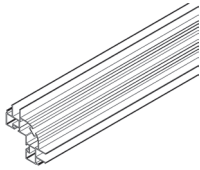
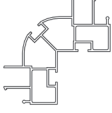
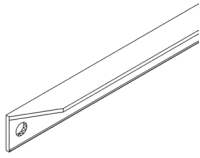

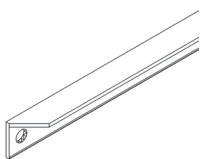
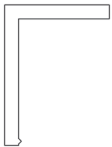

Pakke 1/1 - 3/6 ZE2					Antal stk. / Model					
Kode nr.	Artikel	Montage- trin	Længde i mm	Antal i delpakke	8100	10000	11900	13800	15700	Profil
7034		7b 7c	733	6x	16x	18x	20x	22x	24x	
7036		2	922	1x	1x	1x	1x	1x	1x	
7069		3	1924	2x	4x	4x	4x	4x	4x	
7133		1	2460	2x	2x	2x	2x	2x	2x	
7134		2	2459	2x	2x	2x	2x	2x	2x	
7236		1	1775	2x	4x	4x	4x	4x	4x	

Pakke 1/1 - 4/6					Antal stk. / Model					
Kode nr.	Artikel	Montage- trin	Længde i mm	Antal i delpakke	8100	10000	11900	13800	15700	Profil
1415	PPR 	9	1750	2x	2x	2x	2x	2x	2x	
7005		3	1775	2x	6x	8x	10x	12x	14x	
7006		2	1775	3x	3x	3x	3x	3x	3x	
7069		3	1924	2x	4x	4x	4x	4x	4x	
7236		1	1775	2x	4x	4x	4x	4x	4x	
7269		3	1926	4x	4x	4x	4x	4x	4x	
7295		4a	1531.5	4x	4x	4x	4x	4x	4x	



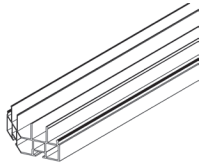
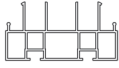
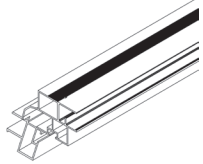
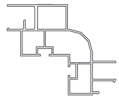
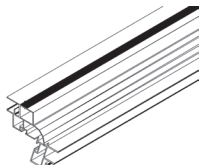
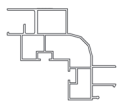
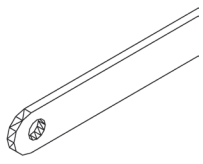

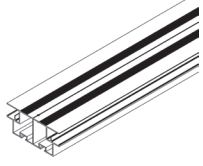

Stykliste

VM0009-Z2

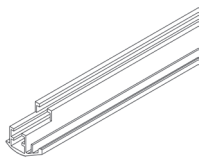
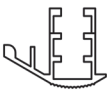
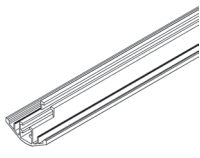
Stykliste

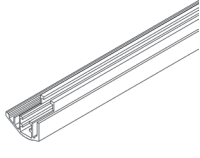
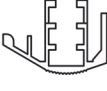
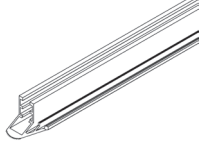

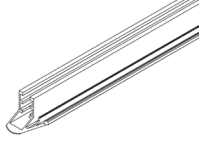
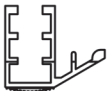
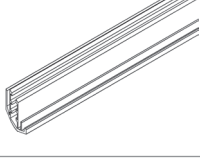
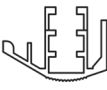
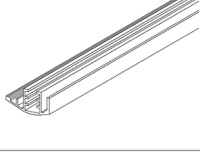
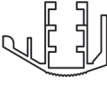
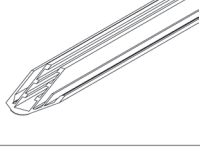
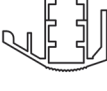
Pakke 1/1 - 5/6					Antal stk. / Model					
Kode nr.	Artikel	Montage- trin	Længde i mm	Antal i delpakke	8100	10000	11900	13800	15700	Profil
7219		3	569.5	2x	2x	2x	2x	2x	2x	
7237		4a	1362	2x	2x	2x	2x	2x	2x	
7238		4a	1362	2x	2x	2x	2x	2x	2x	
7249		4b	1251	1x	3x	4x	5x	6x	7x	
7256		4a	1356	2x	2x	2x	2x	2x	2x	

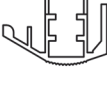

Stykliste

Pakke 1/1 - 6/6					Antal stk. / Model					
Kode nr.	Artikel	Montage- trin	Længde i mm	Antal i delpakke	8100	10000	11900	13800	15700	Profil
7030		7b	1793	2x	2x	2x	2x	2x	2x	
7032		7b	1793	2x	6x	8x	10x	12x	14x	
7033		7b	1793	14x	14x	14x	14x	14x	14x	
7034		7b	733	2x	16x	18x	20x	22x	24x	
7044		7b	443	2x	2x	2x	2x	2x	2x	
7074		7b	1369	2x	2x	2x	2x	2x	2x	
7075		7b	1369	2x	2x	2x	2x	2x	2x	
7276		7b	582	2x	2x	2x	2x	2x	2x	
7277		7b	582	2x	2x	2x	2x	2x	2x	

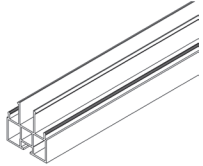
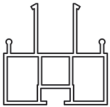
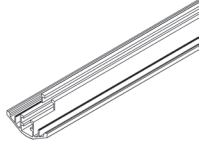
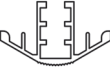
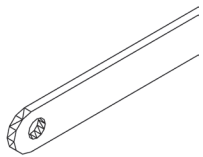

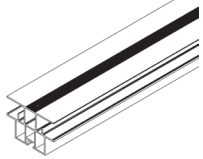
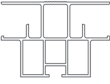

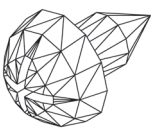
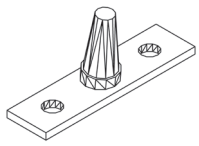
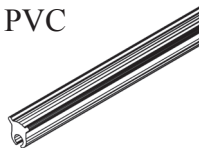
VM0009-Z2

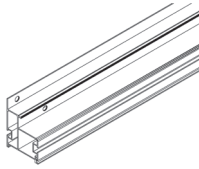
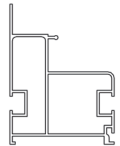
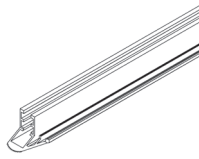
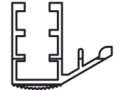
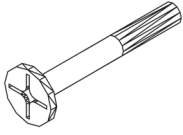
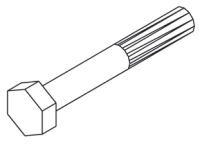
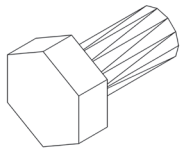
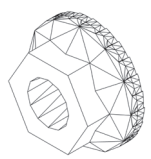
Styklister





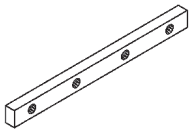
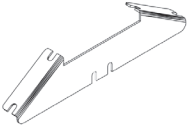

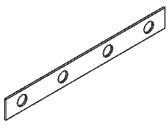
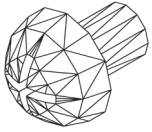
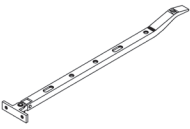
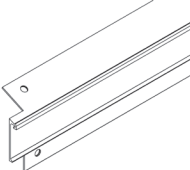
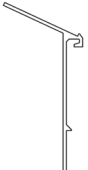

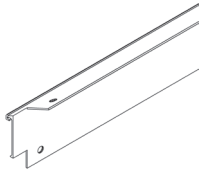

Pakke 1/2					Antal stk. / Model					
Kode nr.	Artikel	Montage- trin	Længde i mm	Antal i delpakke	8100	10000	11900	13800	15700	Profil
7005		3	1775	4x	6x	8x	10x	12x	14x	
7032		7b	1793	4x	6x	8x	10x	12x	14x	
7249		4b	1251	2x	3x	4x	5x	6x	7x	
7255		4b	1356	4x	4x	6x	8x	10x	12x	

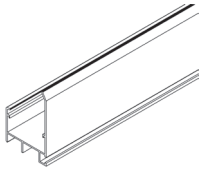
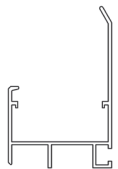
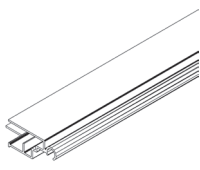
Pakke 2					Antal stk. / Model					
Kode nr.	Artikel	Montage- trin	Længde i mm	Antal i delpakke	8100	10000	11900	13800	15700	Profil
1006		4b 5 6 9	3.5x6	6x	32x	32x	38x	38x	38x	
6056		4b	46	2x	4x	4x	6x	6x	6x	
6090	PVC 	7b 7c	10500	1x	77000	85500	94000	103000	112000	
7001		1	1520	2x	4x	2x	-	-	-	
7034		7b 7c	733	4x	16x	18x	20x	22x	24x	
7047		4b	M6x48	1x	2x	4x	4x	6x	8x	
7050		7b	M6x42	19x	126x	138x	150x	162x	174x	
7052		2, 3 4, 5 6, 7a	M6x12	30x	146x	168x	194x	216x	238x	
7053		1, 2 3, 4 5, 6 7, 8	M6x4	49x	307x	341x	379x	413x	447x	

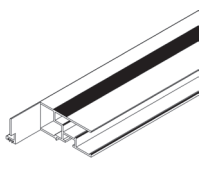
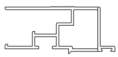
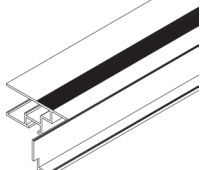
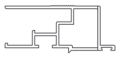
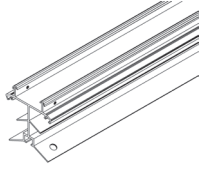
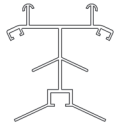
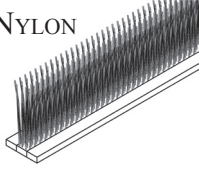

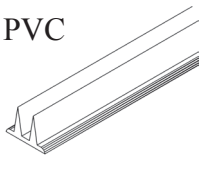

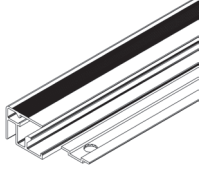

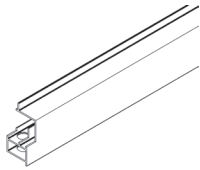
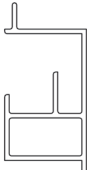
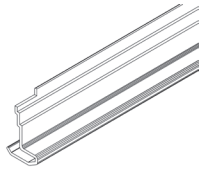
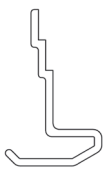
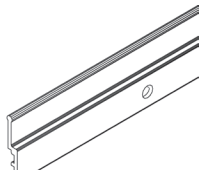

Stykliste

Pakke 2					Antal stk. / Model					
Kode nr.	Artikel	Montage- trin	Længde i mm	Antal i delpakke	8100	10000	11900	13800	15700	Profil
7054		4b 6	M6x100	2x	12x	12x	14x	14x	14x	
7055		4b 6	M6x10 x14	2x	12x	12x	14x	14x	14x	
7061		1 4a 7a	117	2x	13x	15x	17x	17x	17x	
7062		4	235	1x	6x	7x	8x	9x	10x	
7063		3	255	2x	8x	10x	12x	14x	16x	
7064		1 4a 7a	117	2x	5x	5x	5x	5x	5x	
7080		1 4a 7a	M6x8	8x	52x	60x	68x	68x	68x	
7090		5	324	1x	2x	2x	3x	3x	3x	
7201		2	1539	1x	2x	1x	-	-	-	

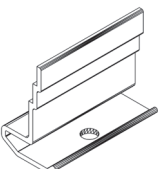
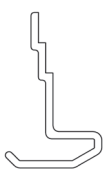
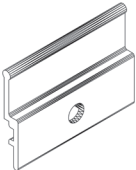
VM0009-Z2

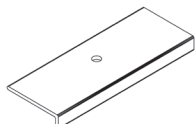
Pakke 2					Antal stk. / Model					
Kode nr.	Artikel	Montage- trin	Længde i mm	Antal i delpakke	8100	10000	11900	13800	15700	Profil
7202		2	1539	1x	2x	1x	-	-	-	
7213		7a	1539	2x	4x	2x	-	-	-	
7244		5	713	1x	2x	2x	3x	3x	3x	
7247 (7291)		5	674	1x	2x	2x	3x	3x	3x	
7248 (7291)		5	674	1x	2x	2x	3x	3x	3x	
7250		4a	1520	1x	2x	1x	-	-	-	
7257	NYLON 	4a	1520	2x	4x	2x	-	-	-	
7291 (7247 & 7248)	PVC 	5	674	2x	4x	4x	6x	6x	6x	
7293		5	713	1x	2x	2x	3x	3x	3x	

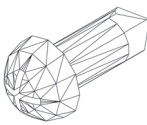
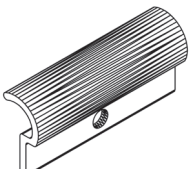
Stykliste

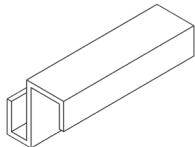
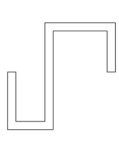

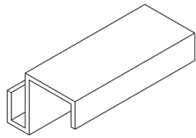
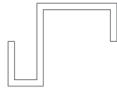



Pakke 2					Antal stk. / Model					
Kode nr.	Artikel	Montage- trin	Længde i mm	Antal i delpakke	8100	10000	11900	13800	15700	Profil
7294		4b	708	1x	2x	2x	3x	3x	3x	
7296		7a	707	4x	8x	10x	12x	14x	16x	
7297		7a	687	4x	8x	10x	12x	14x	16x	
7298		7a*	30	7x	6x +8x*	8x +10x*	9x +12x*	11x +14x*	13x +16x*	
7299		7a*	30	7x	6x +8x*	8x +10x*	9x +12x*	11x +14x*	13x +16x*	
7343		7a	56	2x	4x	6x	8x	10x	12x	
7349		7a* 8	3.9x10	23x	50x	62x	74x	86x	98x	
7369		8	30	2x	4x	4x	6x	6x	6x	
7406		7b	30	4x	14x	16x	18x	20x	22x	



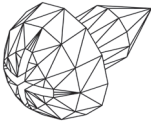
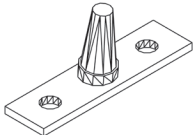

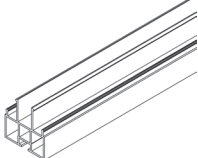
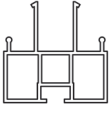
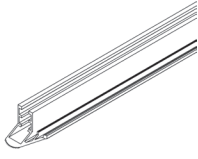
Pakke 2					Antal stk. / Model					
Kode nr.	Artikel	Montage- trin	Længde i mm	Antal i delpakke	8100	10000	11900	13800	15700	Profil
7407		7b	30	4x	14x	16x	18x	20x	22x	

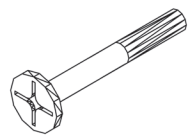
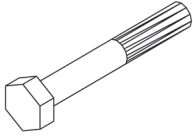
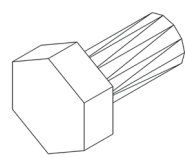
Stykliste



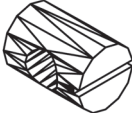
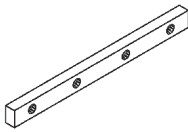
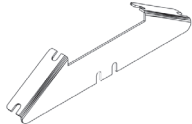

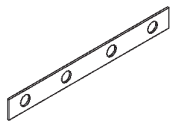
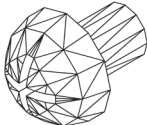
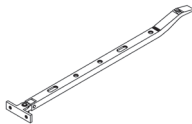
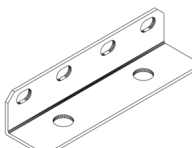



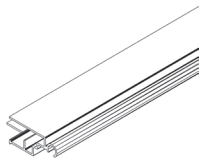
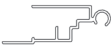
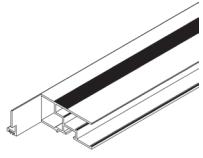

VM0009-Z2

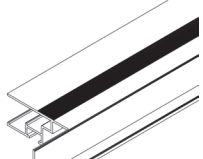

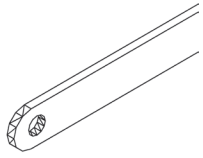

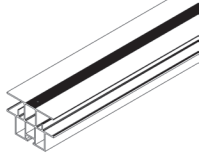
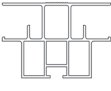
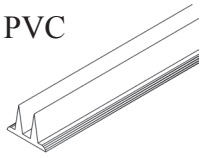

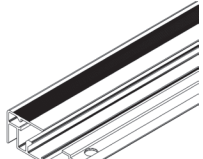

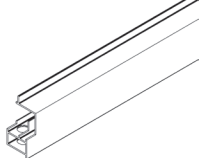
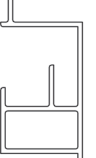
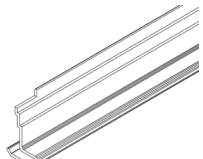
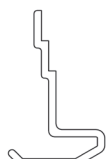

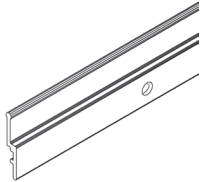
Styklister

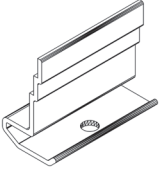
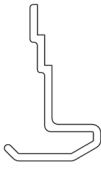
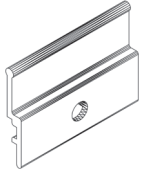
Pakke 3 - 1/2					Antal stk. / Model					
Kode nr.	Artikel	Montage- trin	Længde i mm	Antal i delpakke	8100	10000	11900	13800	15700	Profil
1006		4b 5 6 9	3.5x6	6x	32x	32x	38x	38x	38x	
6056		4b	46	2x	4x	4x	6x	6x	6x	
6090	PVC 	7b 7c	19000	1x	77000	85500	94000	103000	112000	
7005		3	1775	2x	6x	8x	10x	12x	14x	
7034		7b 7c	733	6x	16x	18x	20x	22x	24x	
7047		4b	M6x48	3x	2x	4x	4x	6x	8x	
7050		7b	M6x42	31x	126x	138x	150x	162x	174x	
7052		2, 3 4, 5 6, 7a	M6x12	52x	146x	168x	194x	216x	238x	
7053		1, 2 3, 4 5, 6 7, 8	M6x4	83x	307x	341x	379x	413x	447x	

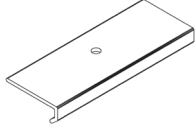
Pakke 3 - 1/2					Antal stk. / Model					
Kode nr.	Artikel	Montage- trin	Længde i mm	Antal i delpakke	8100	10000	11900	13800	15700	Profil
7054		4b 6	M6x100	2x	12x	12x	14x	14x	14x	
7055		4b 6	M6x10 x14	2x	12x	12x	14x	14x	14x	
7061		1 4a 7a	117	4x	13x	15x	17x	17x	17x	
7062		4	235	2x	6x	7x	8x	9x	10x	
7063		3	255	4x	8x	10x	12x	14x	16x	
7064		1 4a 7a	117	2x	5x	5x	5x	5x	5x	
7080		1 4a 7a	M6x8	16x	52x	60x	68x	68x	68x	
7090		5	324	1x	2x	2x	3x	3x	3x	
7095		1	117	2x	8x	10x	12x	12x	12x	

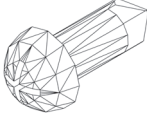
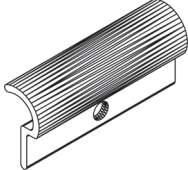
Stykliste

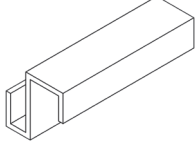
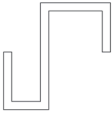
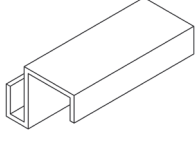



Pakke 3 - 1/2					Antal stk. / Model					
Kode nr.	Artikel	Montage- trin	Længde i mm	Antal i delpakke	8100	10000	11900	13800	15700	Profil
7244		5	713	1x	2x	2x	3x	3x	3x	
7247 (7291)		5	674	1x	2x	2x	3x	3x	3x	
7248 (7291)		5	674	1x	2x	2x	3x	3x	3x	
7249		4b	1251	1x	3x	4x	5x	6x	7x	
7255		4b	1356	2x	4x	6x	8x	10x	12x	
7291 (7247 & 7248)	PVC 	5	674	2x	4x	4x	6x	6x	6x	
7293		5	713	1x	2x	2x	3x	3x	3x	
7294		4b	708	1x	2x	2x	3x	3x	3x	
7296		7a	707	6x	8x	10x	12x	14x	16x	

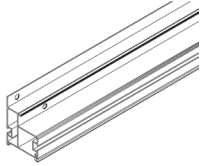
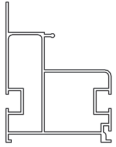
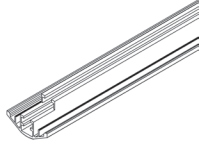
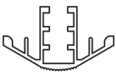
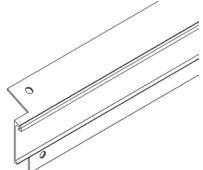

Pakke 3 - 1/2					Antal stk. / Model					
Kode nr.	Artikel	Montage- trin	Længde i mm	Antal i delpakke	8100	10000	11900	13800	15700	Profil
7297		7a	687	6x	8x	10x	12x	14x	16x	
7298		7a*	30	11x	6x +8x*	8x +10x*	9x +12x*	11x +14x*	13x +16x*	
7299		7a*	30	11x	6x +8x*	8x +10x*	9x +12x*	11x +14x*	13x +16x*	
7343		7a	56	4x	4x	6x	8x	10x	12x	
7349		7a* 8	3.9x10	34x	50x	62x	74x	86x	98x	
7369		8	30	2x	4x	4x	6x	6x	6x	
7406		7b	30	6x	14x	16x	18x	20x	22x	
7407		7b	30	6x	14x	16x	18x	20x	22x	

Stykliste

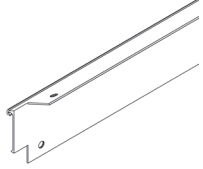
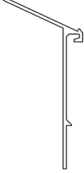
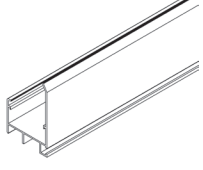
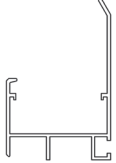
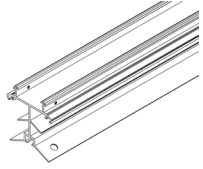
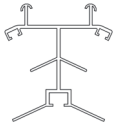
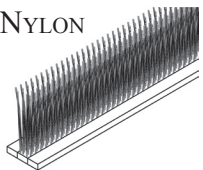



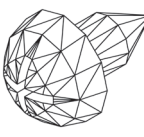
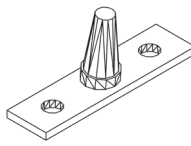

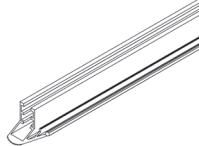
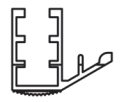
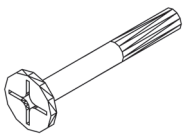
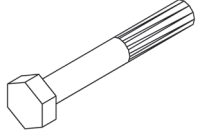
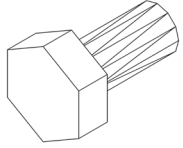
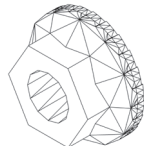
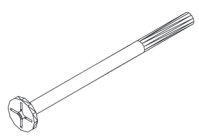
VM0009-Z2



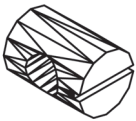
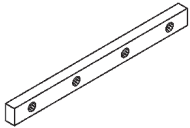
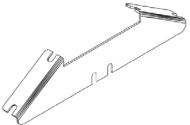

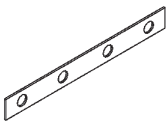
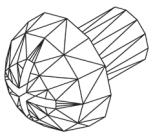
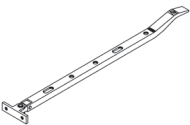
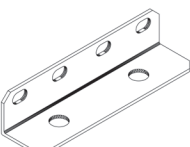

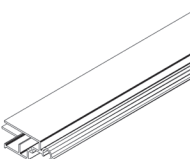
Stykliste

Pakke 3 - 2/2					Antal stk. / Model					
Kode nr.	Artikel	Montage- trin	Længde i mm	Antal i delpakke	8100	10000	11900	13800	15700	Profil
7002		1	2264	2x	-	2x	4x	2x	-	
7032		7b	1793	2x	6x	8x	10x	12x	14x	
7203		2	2283	1x	-	1x	2x	1x	-	
7204		2	2283	1x	-	1x	2x	1x	-	
7214		7a	2283	2x	-	2x	4x	2x	-	
7251		4a	2264	1x	-	1x	2x	1x	-	
7258	NYLON 	4a	2264	2x	-	2x	4x	2x	-	

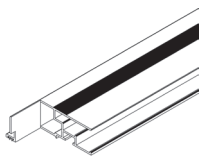
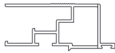
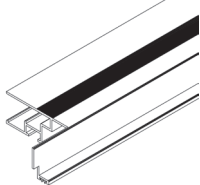

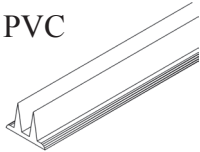

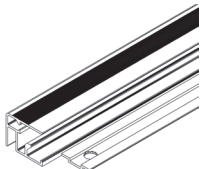

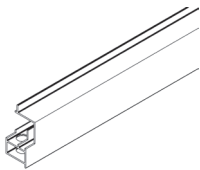
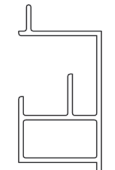
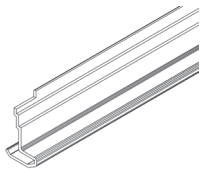
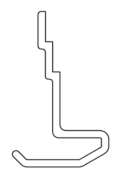
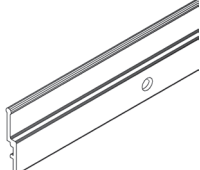
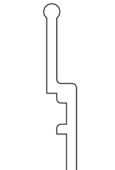
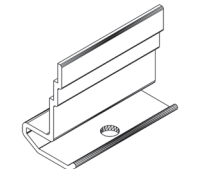
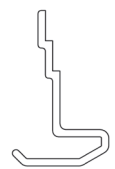
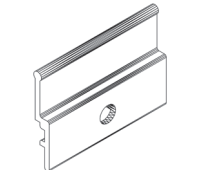
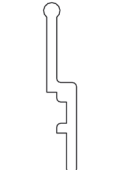

Pakke 4 - 1/2					Antal stk. / Model					
Kode nr.	Artikel	Montage- trin	Længde i mm	Antal i delpakke	8100	10000	11900	13800	15700	Profil
1006		4b 5 6 9	3.5x6	6x	32x	32x	38x	38x	38x	
6056		4b	46	2x	4x	4x	6x	6x	6x	
6090	PVC 	7b 7c	28000	1x	77000	85500	94000	103000	112000	
7034		7b 7c	733	8x	16x	18x	20x	22x	24x	
7047		4b	M6x48	5x	2x	4x	4x	6x	8x	
7050		7b	M6x42	43x	126x	138x	150x	162x	174x	
7052		2, 3 4, 5 6, 7a	M6x12	74x	146x	168x	194x	216x	238x	
7053		1, 2 3, 4 5, 6 7, 8	M6x4	117x	307x	341x	379x	413x	447x	
7054		4b 6	M6x100	2x	12x	12x	14x	14x	14x	

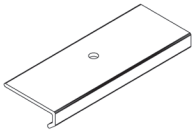

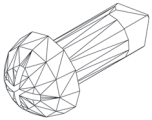
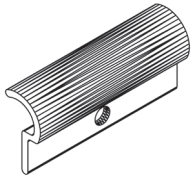

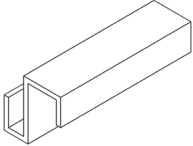
Stykliste

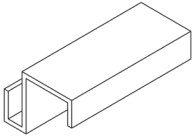
Pakke 4 - 1/2					Antal stk. / Model					
Kode nr.	Artikel	Montage- trin	Længde i mm	Antal i delpakke	8100	10000	11900	13800	15700	Profil
7055		4b 6	M6x10 x14	2x	12x	12x	14x	14x	14x	
7061		1 4a 7a	117	4x	13x	15x	17x	17x	17x	
7062		4	235	3x	6x	7x	8x	9x	10x	
7063		3	255	6x	8x	10x	12x	14x	16x	
7064		1 4a 7a	117	2x	5x	5x	5x	5x	5x	
7080		1 4a 7a	M6x8	16x	52x	60x	68x	68x	68x	
7090		5	324	1x	2x	2x	3x	3x	3x	
7095		1	117	2x	8x	10x	12x	12x	12x	
7244		5	713	1x	2x	2x	3x	3x	3x	



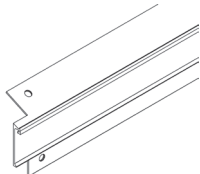

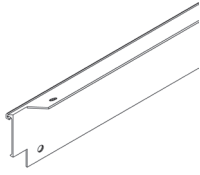
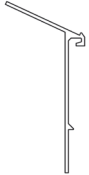
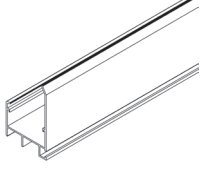
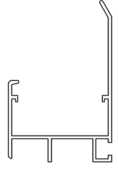
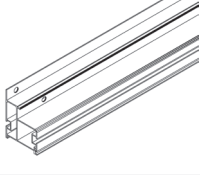
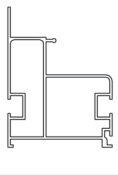
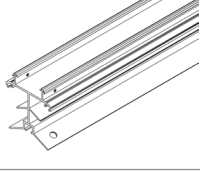
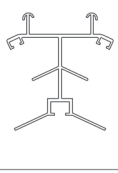
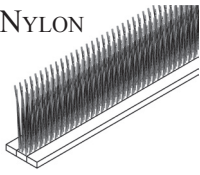
Pakke 4 - 1/2					Antal stk. / Model					
Kode nr.	Artikel	Montage- trin	Længde i mm	Antal i delpakke	8100	10000	11900	13800	15700	Profil
7247 (7291)		5	674	1x	2x	2x	3x	3x	3x	
7248 (7291)		5	674	1x	2x	2x	3x	3x	3x	
7291 (7247 & 7248)	PVC 	5	674	2x	4x	4x	6x	6x	6x	
7293		5	713	1x	2x	2x	3x	3x	3x	
7294		4b	708	1x	2x	2x	3x	3x	3x	
7296		7a	707	8x	8x	10x	12x	14x	16x	
7297		7a	687	8x	8x	10x	12x	14x	16x	
7298		7a*	30	15x	6x +8x*	8x +10x*	9x +12x*	11x +14x*	13x +16x*	
7299		7a*	30	15x	6x +8x*	8x +10x*	9x +12x*	11x +14x*	13x +16x*	



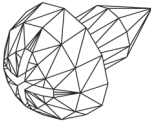
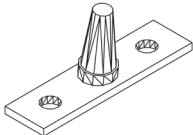
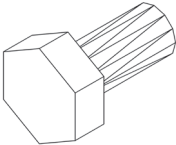

Styklister

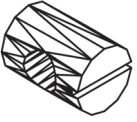
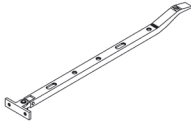
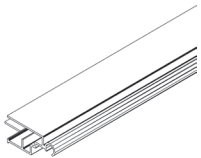
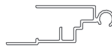
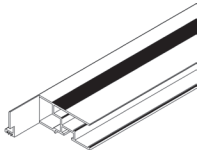
Pakke 4 - 1/2					Antal stk. / Model					
Kode nr.	Artikel	Montage- trin	Længde i mm	Antal i delpakke	8100	10000	11900	13800	15700	Profil
7343		7a	56	6x	4x	6x	8x	10x	12x	
7349		7a* 8	3.9x10	46x	50x	62x	74x	86x	98x	
7369		8	30	2x	4x	4x	6x	6x	6x	
7406		7b	30	8x	14x	16x	18x	20x	22x	
7407		7b	30	8x	14x	16x	18x	20x	22x	

Pakke 4 - 2/2					Antal stk. / Model					
Kode nr.	Artikel	Montage- trin	Længde i mm	Antal i delpakke	8100	10000	11900	13800	15700	Profil
7205		2	3027	1x	-	-	-	1x	2x	
7206		2	3027	1x	-	-	-	1x	2x	
7215		7a	3027	2x	-	-	-	2x	4x	
7224		1	3008	2x	-	-	-	2x	4x	
7252		4a	3008	1x	-	-	-	1x	2x	
7259	NYLON 	4a	3008	2x	-	-	-	2x	4x	

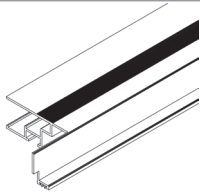
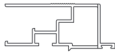
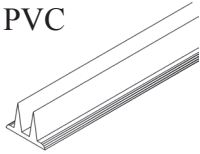
Styklister

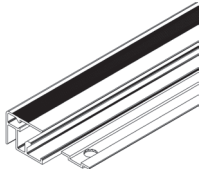
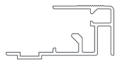
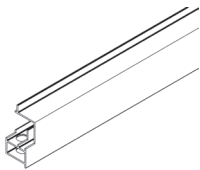
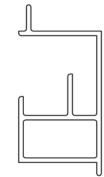
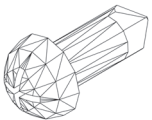
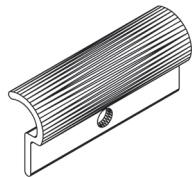
Pakke 5 Ventilationsvindue					Antal stk. / Model					
Kode nr.	Artikel	Montage- trin	Længde i mm	Antal i delpakke	8100	10000	11900	13800	15700	Profil
1006		4b 5 6 9	3.5x6	6x	32x	32x	38x	38x	38x	
6056		4b	46	2x	4x	4x	6x	6x	6x	
7052		2, 3 4, 5 6, 7a	M6x12	4x	146x	168x	194x	216x	238x	
7053		1, 2 3, 4 5, 6 7, 8	M6x4	4x	307x	341x	379x	413x	447x	
7054		4b 6	M6x100	2x	12x	12x	14x	14x	14x	
7055		4b 6	M6x10 x14	2x	12x	12x	14x	14x	14x	
7090		5	324	1x	2x	2x	3x	3x	3x	
7244		5	713	1x	2x	2x	3x	3x	3x	
7247 (7291)		5	674	1x	2x	2x	3x	3x	3x	

Pakke 5 Ventilationsvindue					Antal stk. / Model					
Kode nr.	Artikel	Montage- trin	Længde i mm	Antal i delpakke	8100	10000	11900	13800	15700	Profil
7248 (7291)		5	674	1x	2x	2x	3x	3x	3x	
7291 (7247 & 7248)	PVC 	5	674	2x	4x	4x	6x	6x	6x	
7293		5	713	1x	2x	2x	3x	3x	3x	
7294		4b	708	1x	2x	2x	3x	3x	3x	
7349		7a* 8	3.9x10	2x	50x	62x	74x	86x	98x	
7369		8	30	2x	4x	4x	6x	6x	6x	



VIGTIGT:

Materialer eller værktøj, der skal anvendes til fremstilling af fundamentet / soklen indgår ikke i leverancen.



Oplysninger vedr. fundamentet er at betragte som vejledende forslag.

Drivhuset skal opstilles på et stabilt fundament / sokkel. Soklen kan laves f.eks. som en fuldstøbt betonsokkel eller bygges op i mursten eller Leca-sten.

Soklen skal gå ned i frostfri dybde (80-90 cm) for at undgå skævvridninger.

Såfremt De er usikker på soklens konstruktion, anbefaler vi Dem at kontakte en fagmand.

Sokkelmålene fremgår af tabellen på side 39. Vær opmærksom på, at der til senere fastgørelse af bundramme skal være 50 mm plads enten på yder- eller på indersiden af bundrammen, se illustrationen på side 39.



VIGTIGT:

Soklen skal være meget nøjagtigt i vater og de fire hjørner skal være retvinklede. Anvend et langt vaterpas og en stor vinkel til dette.







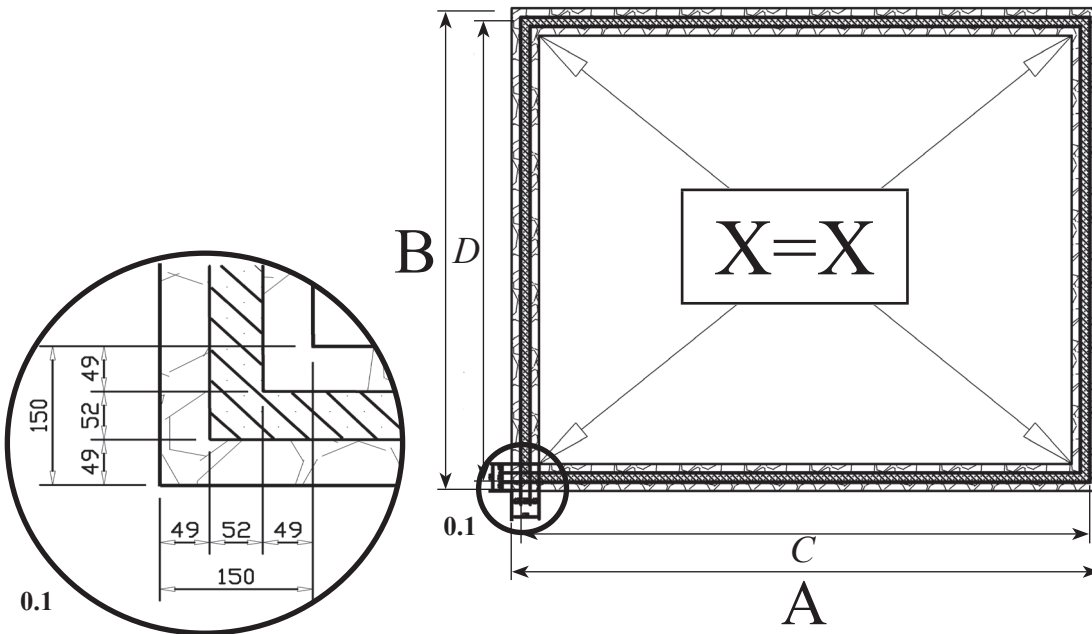
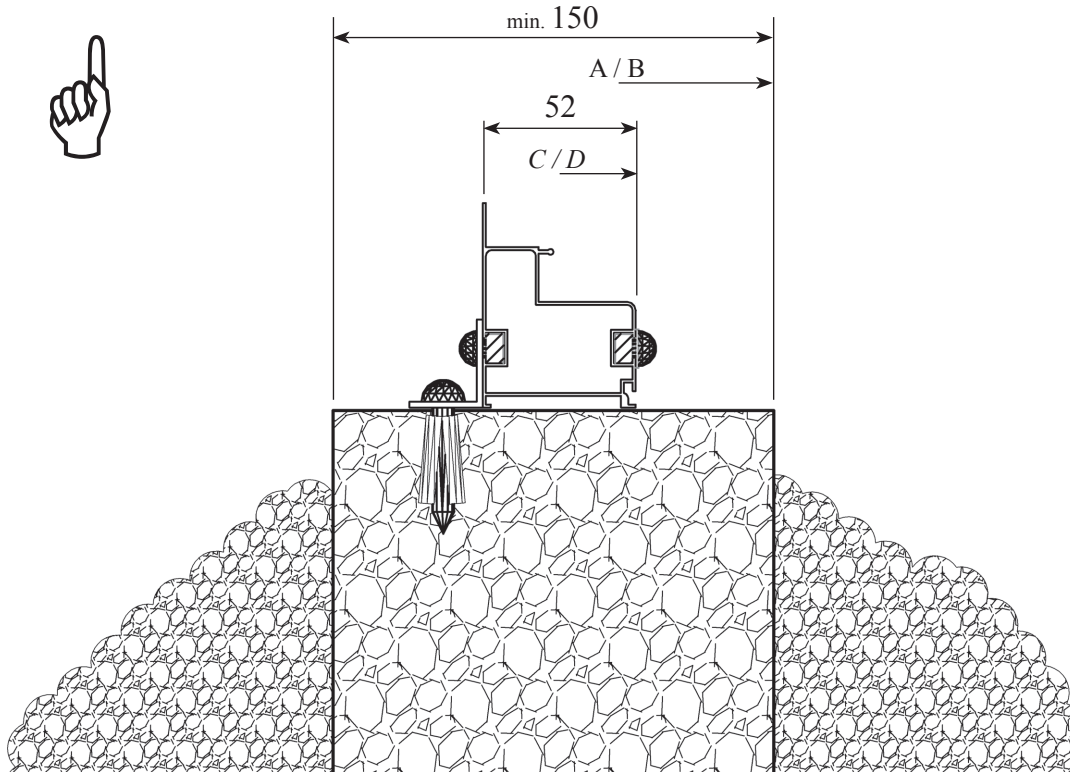





Tip: Sørg for, at de to X-mål som vist på tegningen side 39 er helt ens. Dermed er De sikker på, at de fire hjørner er retvinklede.

Byg derefter drivhuset ovenpå det færdige fundament.

Bundrammen skal først fastgøres til fundamentet, når hele drivhuset er færdigmonteret, og alt er i vater, lod og vinkel.



	8100	10000	11900	13800	15700
A	3242 mm	3986 mm	4730 mm	5474 mm	6218 mm
B	2662 mm	2662 mm	2662 mm	2662 mm	2662 mm
C	(3144 mm)	(3888 mm)	(4632 mm)	(5376 mm)	(6120 mm)
D	(2564 mm)	(2564 mm)	(2564 mm)	(2564 mm)	(2564 mm)

Model				
8100	10000	11900	13800	15700
				
4x	2x	-	-	-
				
-	2x	4x	2x	-
				
8x	8x	8x	8x	8x
				
10x	12x	14x	14x	14x
				
2x	2x	2x	2x	2x
				
40x	48x	56x	56x	56x
				
8x	10x	12x	12x	12x
				
2x	2x	2x	2x	2x
				
4x	4x	4x	4x	4x
				
-	-	-	2x	4x
				
4x	4x	4x	4x	4x
				
8x	8x	8x	8x	8x

1.1	KODE 1 – KODE 2	LÆNGDE
8100	7001-7001	1520 + 1520 mm
10000	7001-7002	1520 + 2264 mm
11900	7002-7002	2264 + 2264 mm
13800	7002-7224	2264 + 3008 mm
15700	7224-7224	3008 + 3008 mm

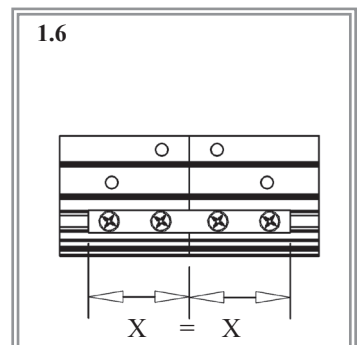
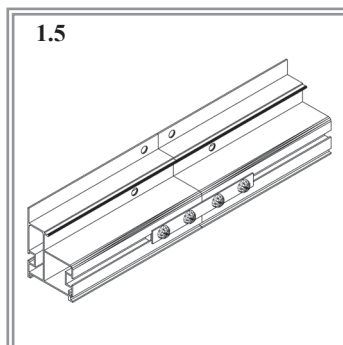
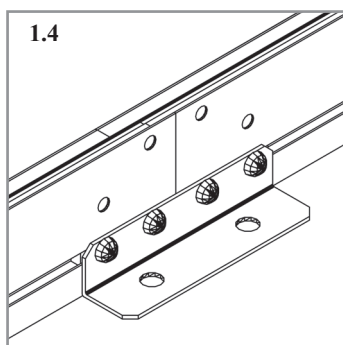
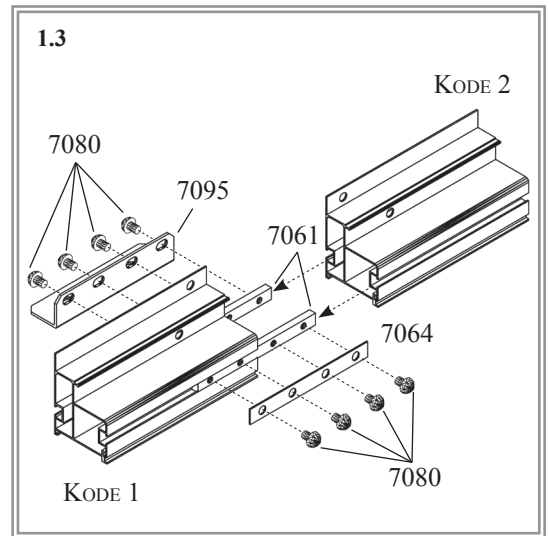
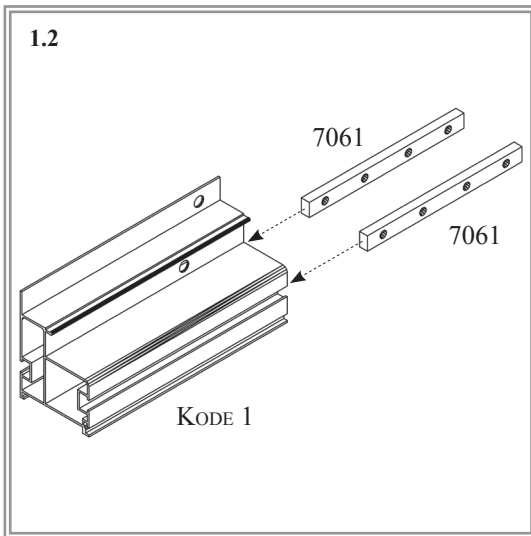
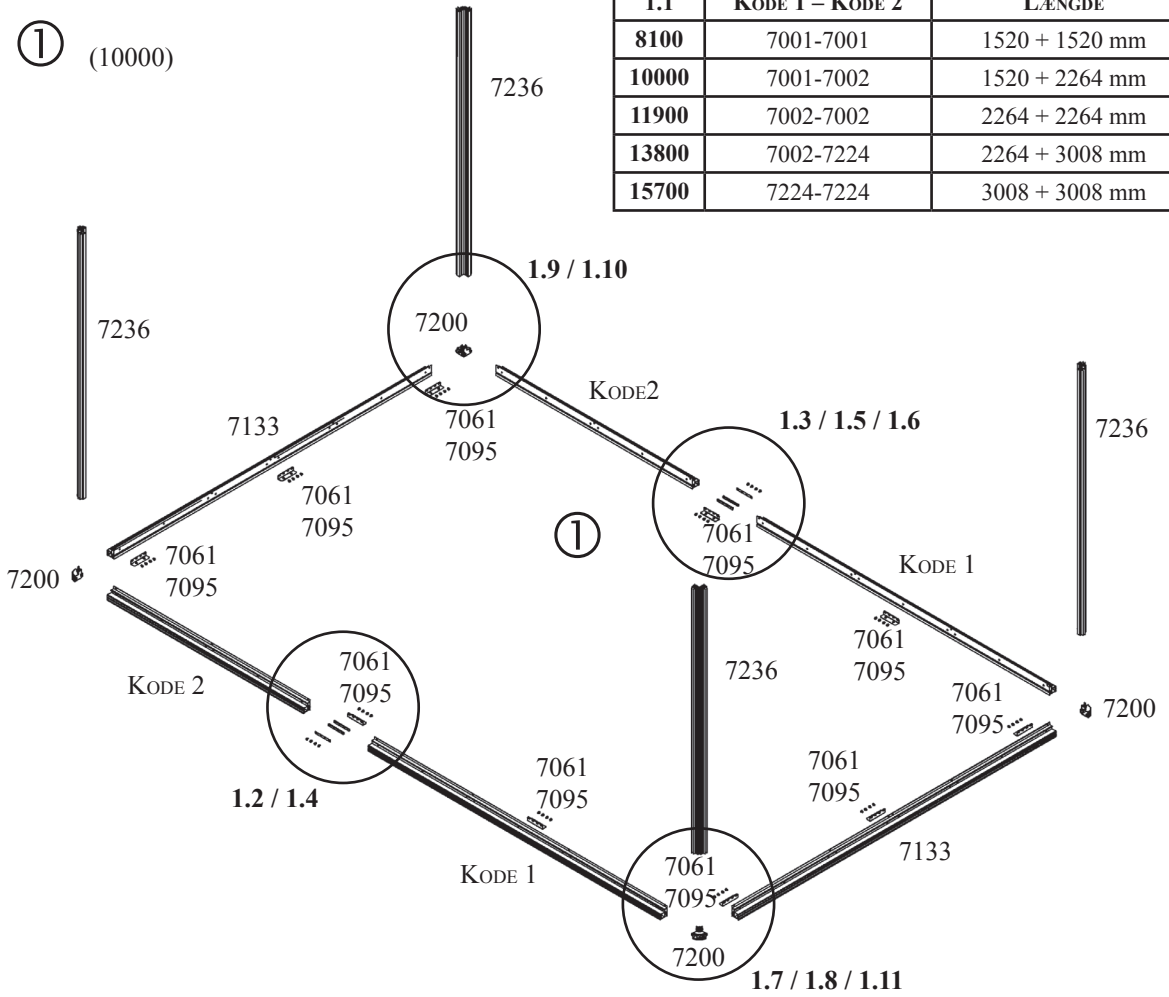

BUNDRAMME / HJØRNESTOLPER

BEMÆRK VENLIGST:

Bundrammen skal først skrues fast på fundamentet ved hjælp af vinkel (7095), når alle øvrige dele i drivhuskonstruktionen er monteret.

Der bør være minimum to personer til at samle og montere dette drivhus.



Tegninger med enkeltramme (f.eks. 1.9) er set indefra.

Tegninger med dobbeltramme (f.eks. 1.7) er set udefra.

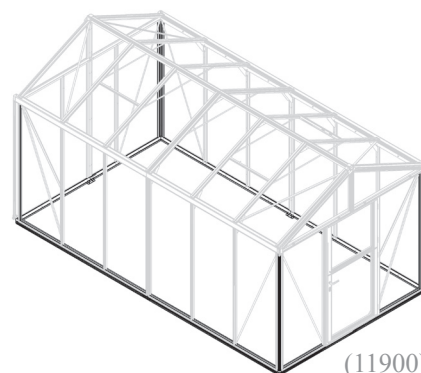

Tag bundrammeprofilerne 7133 ud af henholdsvis del pakke 1/1-3/6, og læg profilerne på jorden som vist på den store ill. ① på side 40. Dernæst de 4 modelspecifikke bundrammeprofiler 7001, 7002 eller 7224 fra delpakke 2, 3 eller se tabel (1.1) og saml disse to og to ved hjælp af samlestykke 7061 (1.2). Ved hjælp af bolt 7080 (1.3) spændes samlestykke 7061 og laske 7064 henholdsvis 7095 løst sammen. Samlestykkerne skal placeres i midten (1.6). Derefter fastspændes bolte 7080.

Efterfølgende forbindes de fire bundprofiler ved hjælp af de afrundede plastichjørnesamlebeslag 7200 (1.7/1.8) og med hjørnestolperne 7236 (1.9/1.10).

Hver hjørnestolpe fastgøres for neden med 2 bolte 7399 og to møtrikker 7053 (1.9. – 1.11). Først spændes møtrikkerne løst på, derefter føres hjørnestolperne ned over bolthovederne. Sørg for, at bolthovederne vender således, at de ubesværet kan glide ind i sporet på hjørnestolperne. Spænd derefter møtrik 7053.

Når alle fire hjørner er samlet, kontrolleres det, at profilerne danner en ret vinkel.

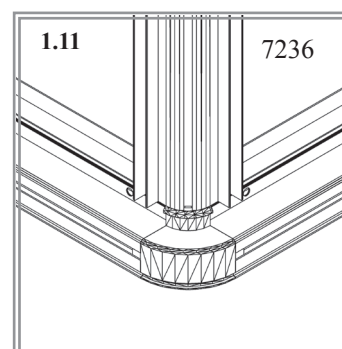
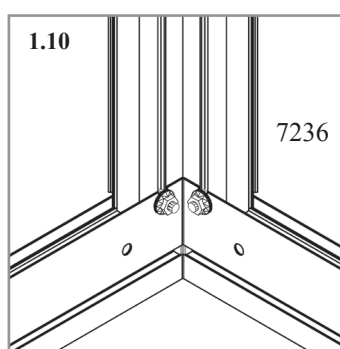
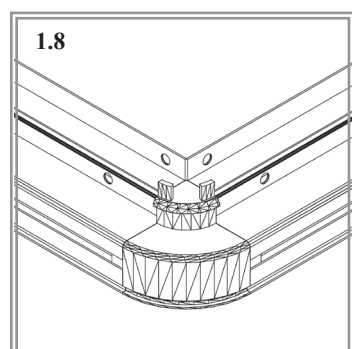
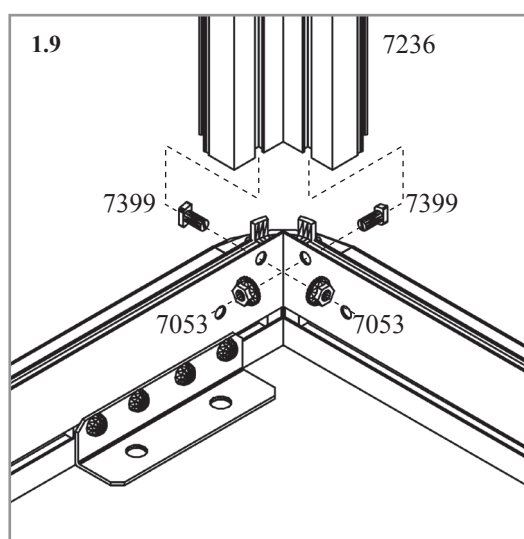
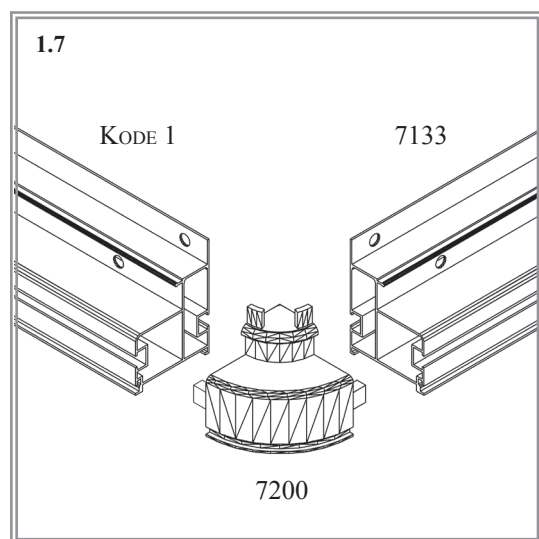

Model				
8100	10000	11900	13800	15700
7006				
3x	3x	3x	3x	3x
7036				
1x	1x	1x	1x	1x
7045				
1x	1x	1x	1x	1x
7052				
32x	32x	32x	32x	32x
7053				
36x	36x	36x	36x	36x
7115				
1x	1x	1x	1x	1x
7134				
2x	2x	2x	2x	2x
7201				
2x	1x	-	-	-
7202				
2x	1x	-	-	-
7203				
-	1x	2x	1x	-
7204				
-	1x	2x	1x	-
7205				
-	-	-	1x	2x
7206				
-	-	-	1x	2x
7390				
4x	4x	4x	4x	4x

② (10000)

2.1	TAGREM 1-2-3-4	LÆNGDE (TAGREM 1/2) + (TAGREM 3/4)
8100	7201-7202-7201-7202	1539 + 1539 mm
10000	7201-7202-7203-7204	1539 + 2283 mm
11900	7203-7204-7203-7204	2283 + 2283 mm
13800	7203-7204-7205-7206	2283 + 3027 mm
15700	7205-7206-7205-7206	3027 + 3027 mm

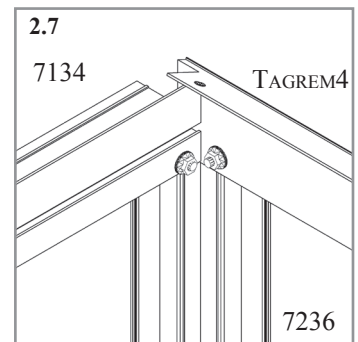
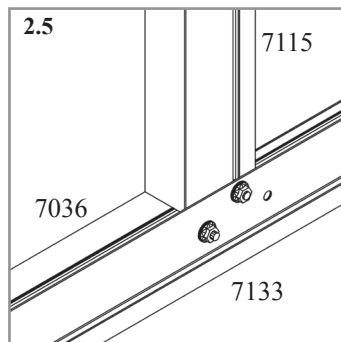
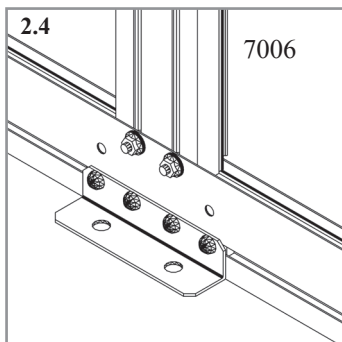
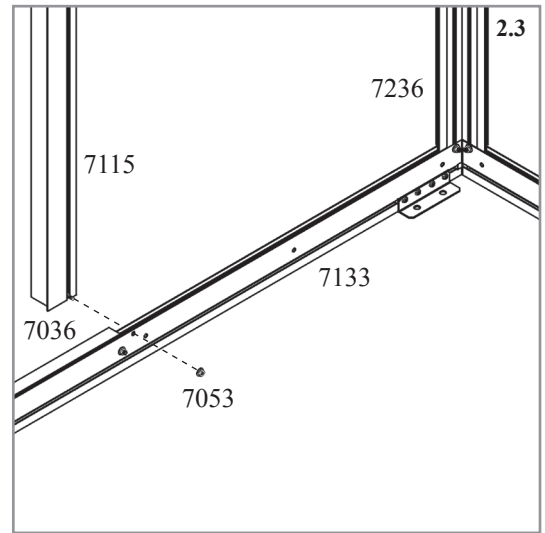
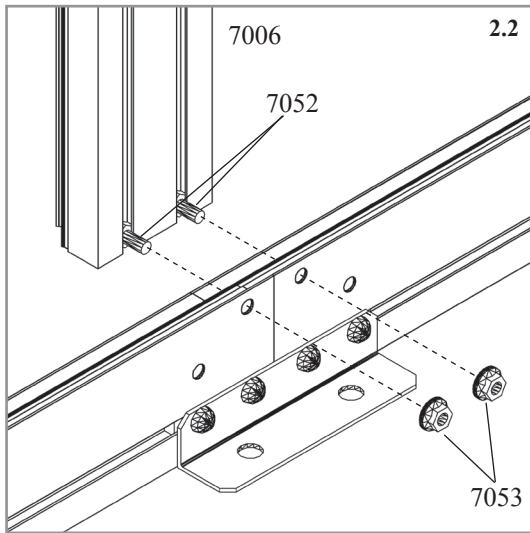
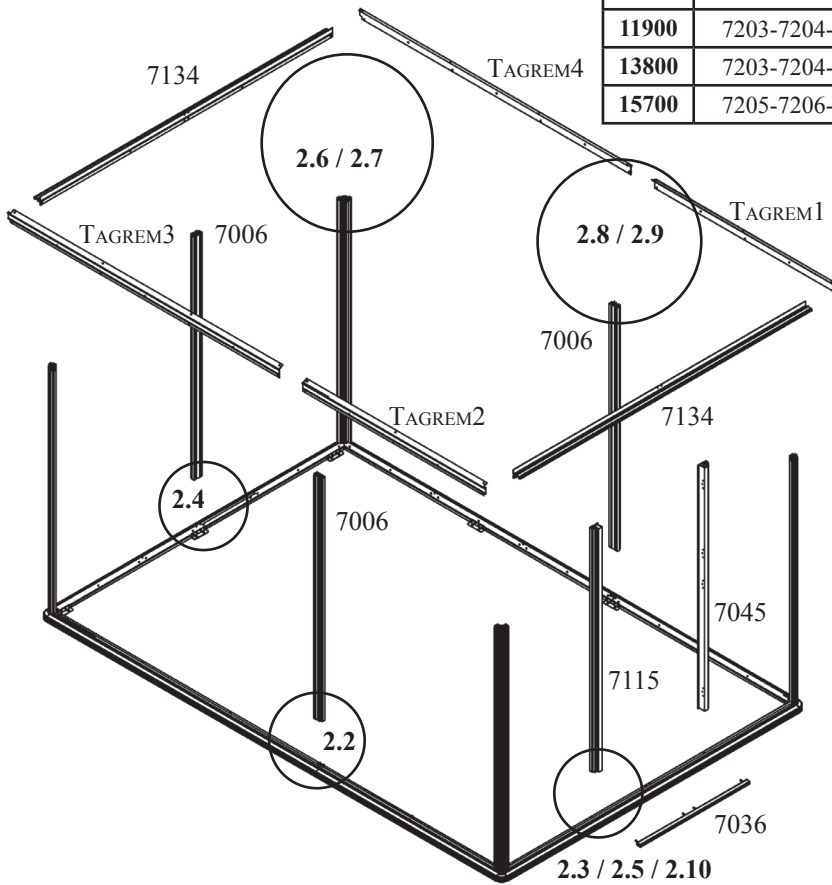

VM0009-Z2

MIDTERPROFIL I LANGSIDE / TAGREM I GAVLE

BEMÆRK VENLIGST:

Til dette trin i opbygningsprocessen bør der være 2 eller 3 personer.

Møtrikker skal kun spændes let. Møtrikkerne skal senere afmonteres for at muliggøre montering af yderligere profiler.

Detaljetegningerne er set indefra.

„Tombolt“ (ekstra-bolt) = Bolt og møtrik uden synlig funktion i starten; skal anvendes til senere fastgørelse af dele.

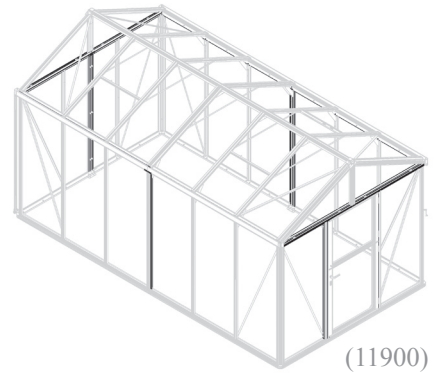

Start med at anbringe 4 bolte 7390 i bundlisten i døren 7036. Forbind 7036 med bundliste 7133; dette gøres udefra i døråbningen. (2.3) (2.10)

Indsæt to tombolte 7052 i hvert boltspor på 2 midterprofiler 7006 og fastgør tomboltene med hver sin møtrik 7053. Tomboltene skal senere anvendes til at fastgøre samlebeslag 7063 (2.9). Ved hjælp af bolt 7052 og møtrik 7053 fastgøres de klargjorte profiler 7006 til bundrammen, se illustration 2.2.

Der skal ikke en tombolt i mellemprofil 7006 på baggavlen.





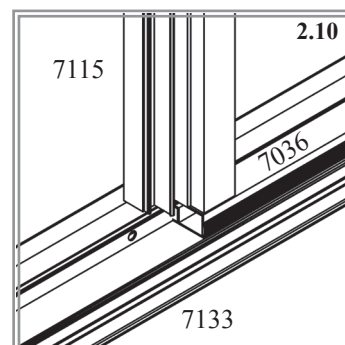
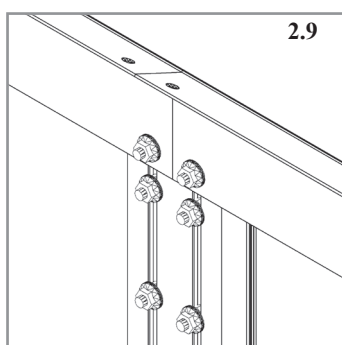
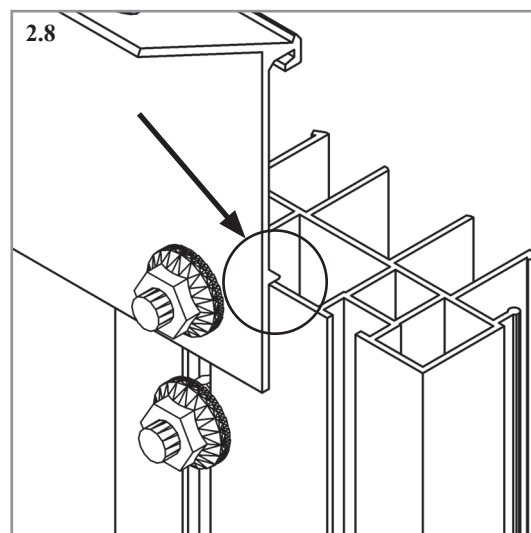
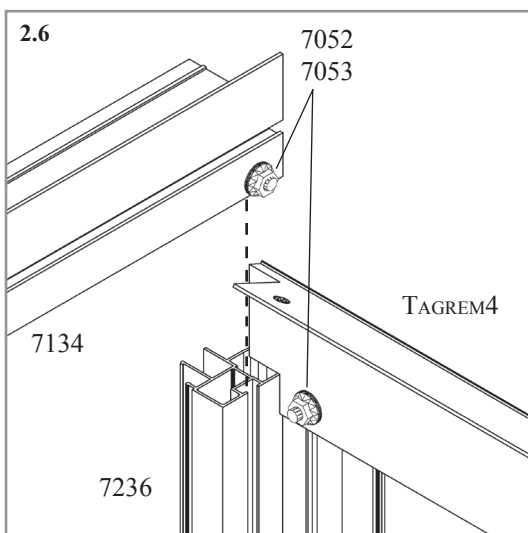

Fastgør langsides mellemprofil 7006 og hjørnestolpe 7007 til tagremmen tabel (2.1), ill. (2.6 -2.9). Bemærk montageflangen (2.8). Vær omhyggelig med at sikre, at tagremmene skubbes ind i hjørnet af 7236 (2.6) og sikr at flangen sidder rigtigt (2.8).

Til sidst monteres de klargjorte profiler 7134 til henholdsvis hjørnestolpe 7236 i for- og baggavl ved hjælp af bolt 7052 og møtrik 7053 (2.6 / 2.7). Forbind mellemprofiler 7006 i baggavlen og 7045 og 7115 i dørgavlen til bundprofilen og overliggerne 7134 ved at skubbe bolt 7052 ind i boltsporet og fastspænde møtrik 7053 (2.2 – 2.5).



Midterprofil i langside / tagrem i gavle

VM0009-Z2

Model				
8100	10000	11900	13800	15700
7005 				
6x	8x	10x	12x	14x
7052 				
28x	36x	44x	52x	60x
7053 				
28x	36x	44x	52x	60x
7063 				
8x	10x	12x	14x	16x
7069 				
4x	4x	4x	4x	4x
7219 				
2x	2x	2x	2x	2x
7269 				
4x	4x	4x	4x	4x

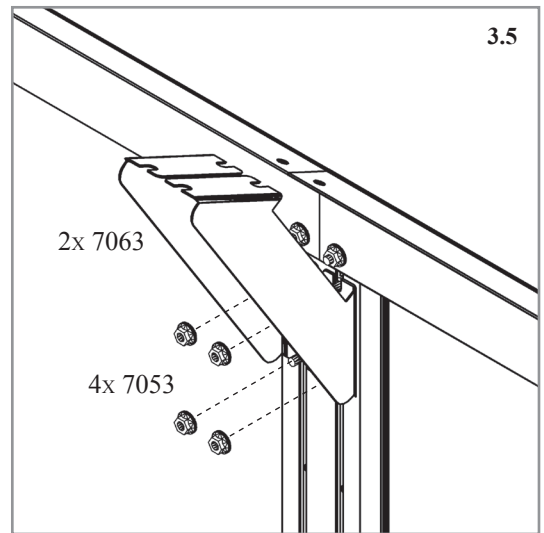
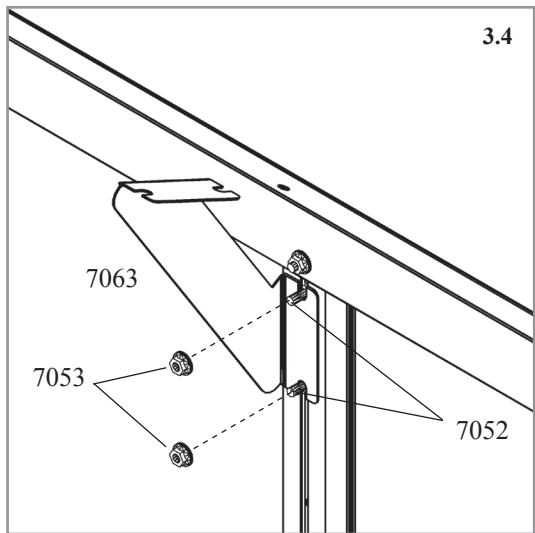
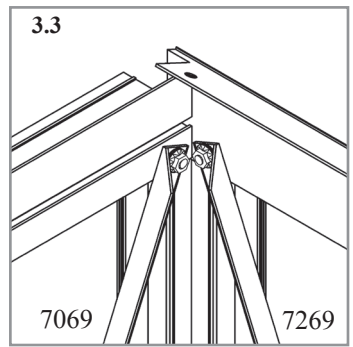
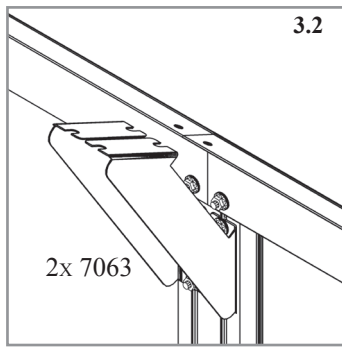
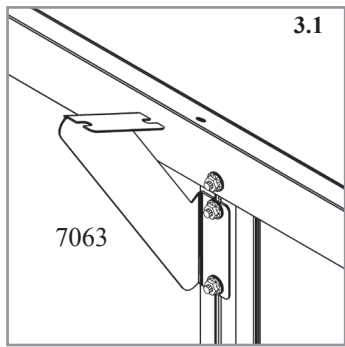
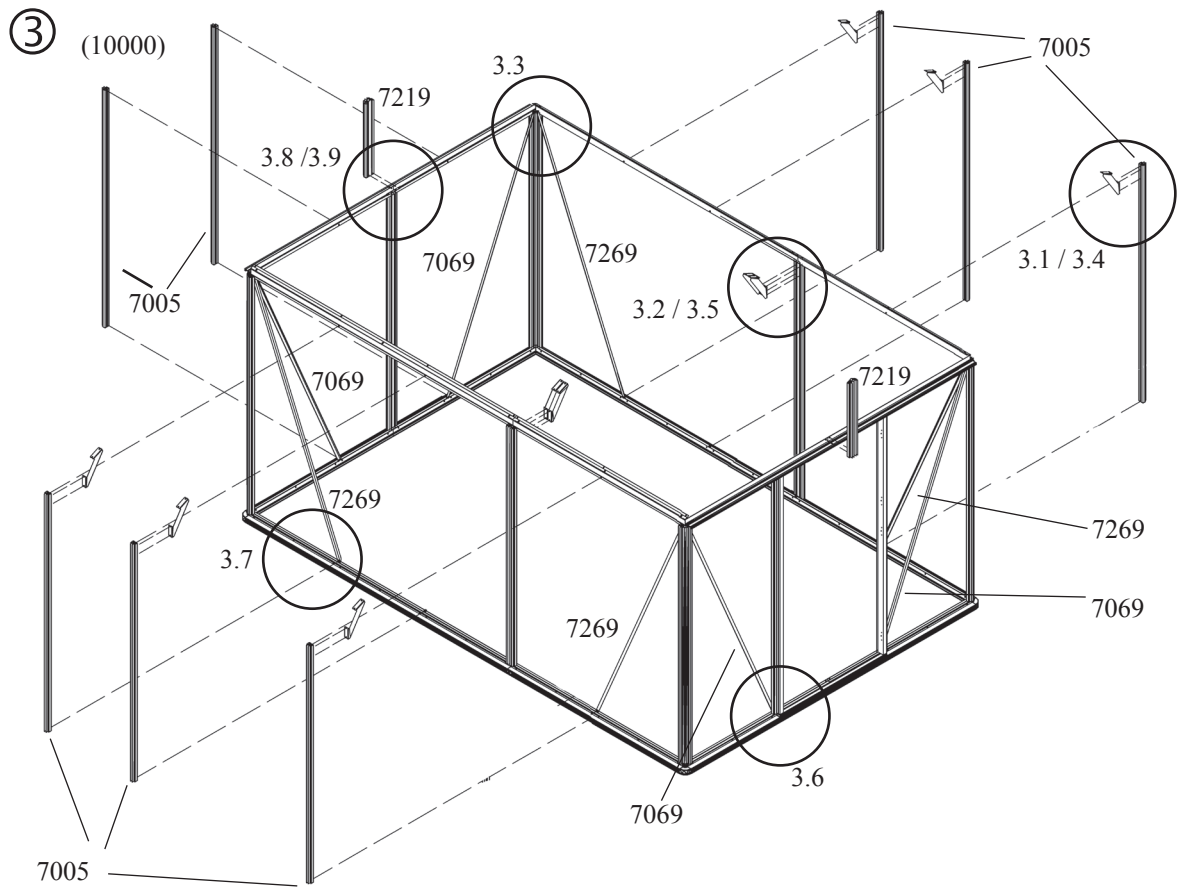

MELLEMPROFILER

BEMÆRK VENLIGST:

I denne opbygningsfase monteres vindsikringsprofilerne (de diagonale skråstivere) 7069 og 7269. Nogle af de allerede monterede bolte og møtrikker skal løsnes igen. Det kan forekomme, at skråstiverne synes at være for lange eller for korte. Ved at bevæge stellet (de samlede profiler) let frem og tilbage rettes huset ud, så skråstivernes længde passer.

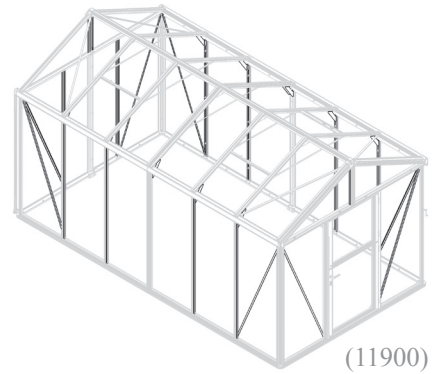

I sporet på henholdsvis 4 / 6 / 8 / 10 / 12 (afhængigt af model 8100 / 10000 / 11900 / 13800 / 15700) mellemprofiler 7005 anbringes to tombolte 7052. Fastgør boltene løst med en møtrik 7053 hver.

Som vist på den store ill. ③ fastgøres de forberedte profiler 7005 til sidevæggene. Fastgør samlebeslag 7063 til de forberedte profiler 7005 og 7006 ved sidevæggene (3.1, 3.2, 3.4, 3.5). Samlebeslagenes 7063 nøjagtige placering (højden) afgøres først senere. I bag gavlen monteres to mellemprofiler 7005 uden tombolte som vist på ill ③.

Fastgør skråstiverne 7069 og 7269 (3.3/3.6/3.7). Det kan forekomme, at skråstiverne synes at være for lange eller for korte. Ved at bevæge stellet (de samlede profiler) let frem og tilbage (diagonalt) rettes huset ud, så skråstivernes længde passer.

Tagrygstøtterne 7019 (3.8 / 3.9) monteres, og der anbringes en tombolt 7052 med møtrik 7053 i hvert af de to profilspor i 7219, se (3.8) og (4a.3).

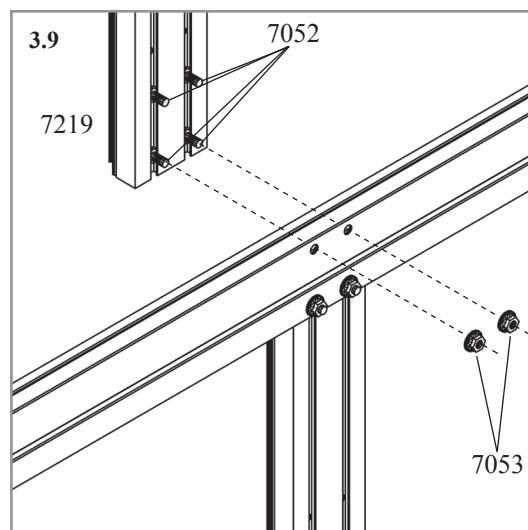
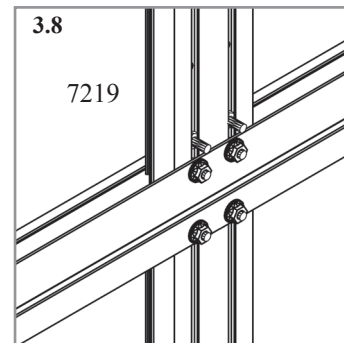
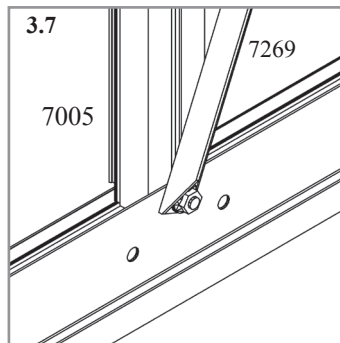
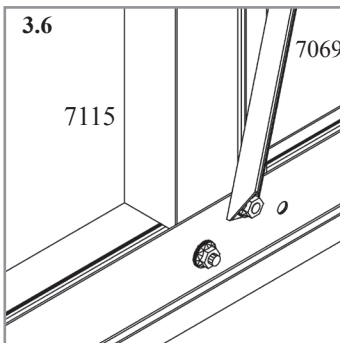

Mellemprofiler

VM0009-Z2

4a

④ a (10000)

4A.1	TAGRYG 1 – TAGRYG 2	LÆNGDE
8100	7250-7250	1520 + 1520 mm
10000	7250-7251	1520 + 2264 mm
11900	7251-7251	2264 + 2264 mm
13800	7251-7252	2264 + 3008 mm
15700	7252-7252	3008 + 3008 mm

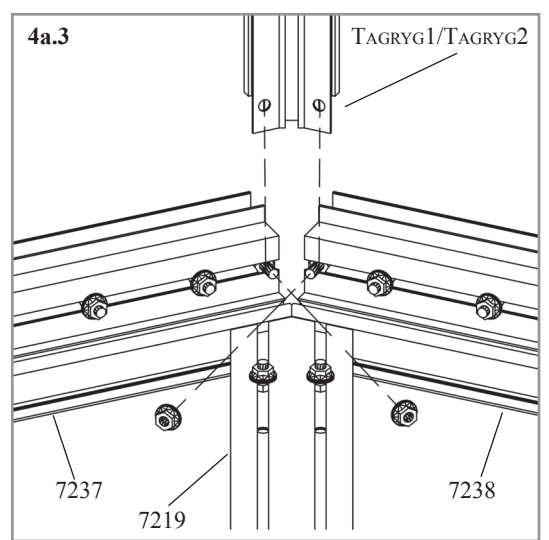
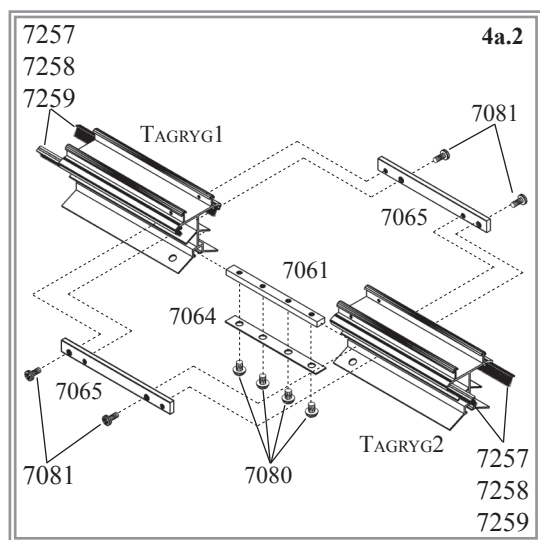
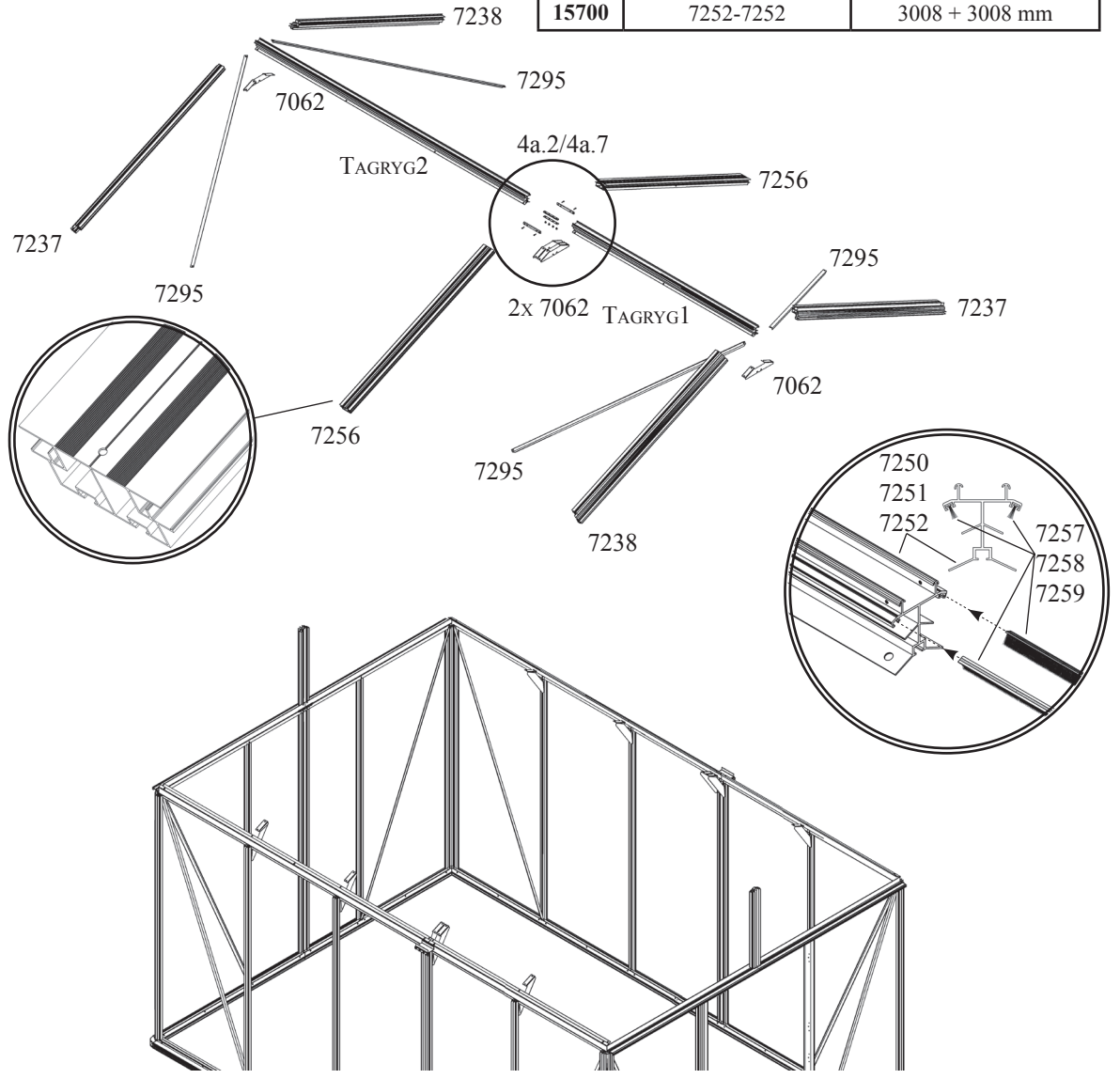

Model				
8100	10000	11900	13800	15700
7052				
40x	40x	40x	40x	40x
7053				
40x	40x	40x	40x	40x
7061				
1x	1x	1x	1x	1x
7062				
4x	4x	4x	4x	4x
7064				
1x	1x	1x	1x	1x
7065				
2x	2x	2x	2x	2x
7080				
4x	4x	4x	4x	4x
7081				
4x	4x	4x	4x	4x
7237				
2x	2x	2x	2x	2x
7238				
2x	2x	2x	2x	2x
7250				
2x	1x	-	-	-
7251				
-	1x	2x	1x	-
7252				
-	-	-	1x	2x
7256				
2x	2x	2x	2x	2x
7257				
4x	2x	-	-	-
7258				
-	2x	4x	2x	-
7259				
-	-	-	2x	4x
7295				
4x	4x	4x	4x	4x

VM0009-Z2

TAGRYG / TAGPROFILER

BEMÆRK VENLIGST:

Til dette trin i opbygningsprocessen bør der være to eller tre personer. De får brug for en eller gerne to stiger.

Nogle møtrikker 7053 skal løsnes for at muliggøre montering af yderligere profiler.

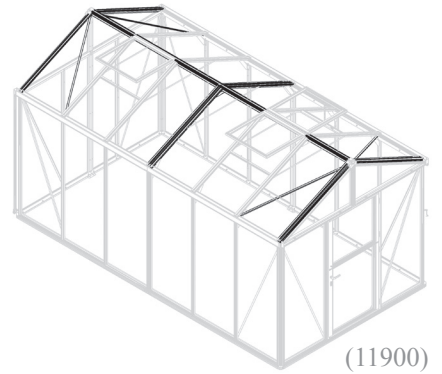

Forbered tagryggen til påsætning ved at parre tagrygsdelene som vist i tabel 4a.1. Skub plastic tætningsliste 7257, 7258 eller 7259 ind i kanalerne på begge sider af tagryggen som vist i den største cirkel.

Nu samles tagryggens to dele ved hjælp af tagrygsamlebeslagene 7061 / 7064 / 7080 og 7065 / 7081.

Læg tagryggen midlertidigt til side og anbring to tombolte 7052 i profilerne 7237 og 7238 og spænd disse let fast med møtrikker 7053 (4a.3). Disse skal senere anvendes til fastgørelse af tagafstiver/rygningsbeslag 7062.

Anbring gavlprofil 7237 og 7238 på tagrygstøtten 7219 (4a.3) og (4a.4) og spænd først profilen fast forneden ved tagremmen ved hjælp af bolt 7052 og møtrik 7053. Gentag dette trin i den modsatte gavl.

Nu forbindes den klargjorte tagryg med gavlprofilerne 7237 og 7238 (4a.5). Monter rygningsbeslag 7062 med de formonterede tombolte i 7219, 7237 og 7238 (4a.6). Derefter monteres diagonalafstiverne 7295 mellem tagryggen (4a.6) og tagremmen (4a.8).

Forbered tagmellemprofiler 7256 ved at fastgøre 4 tombolte 7052 med møtrik 7053 i hver og monter dem mellem tagryggen og tagremmen (se den store ill. 4a). Vær opmærksom på, at det lille hul på den udvendige side af 7256 vender mod tagremmen.

Til sidst monteres de dobbelte rygningsbeslag 7062 ved tagryggen (4a.7) og samlebeslag 7063 ved tagremmen (4a.8).

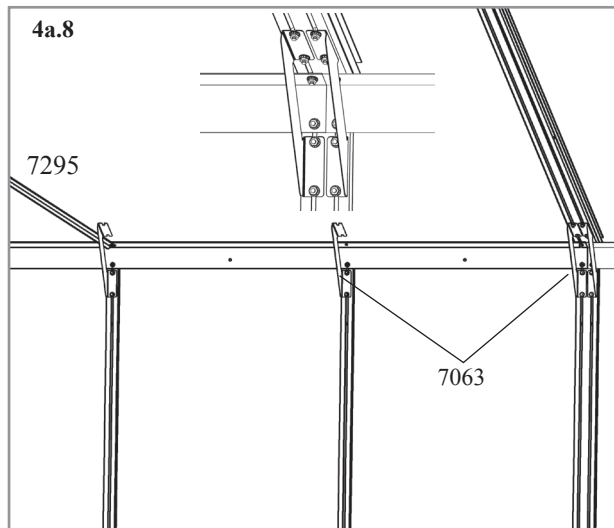
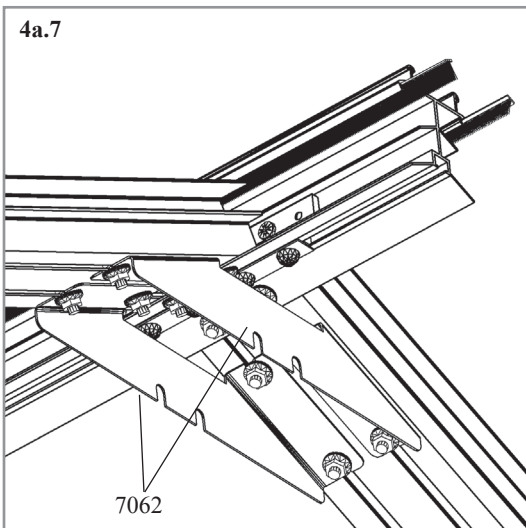
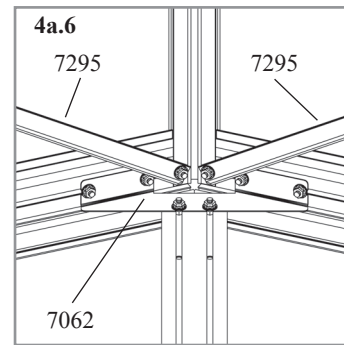
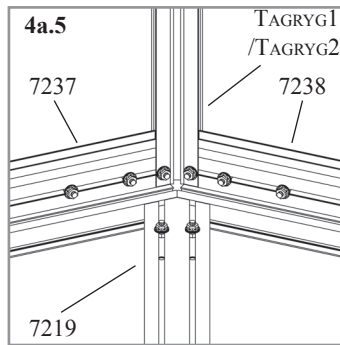
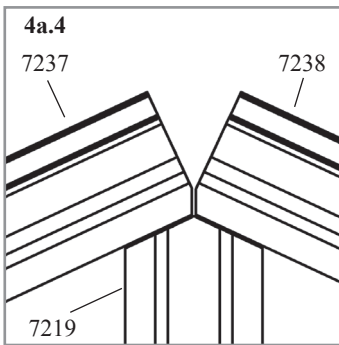

4b

④b (10000)

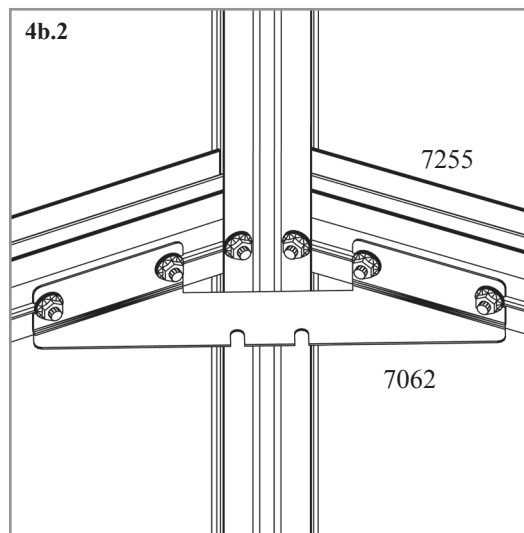
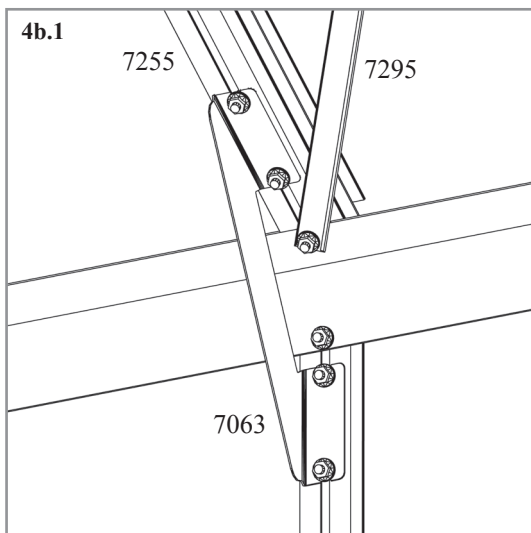
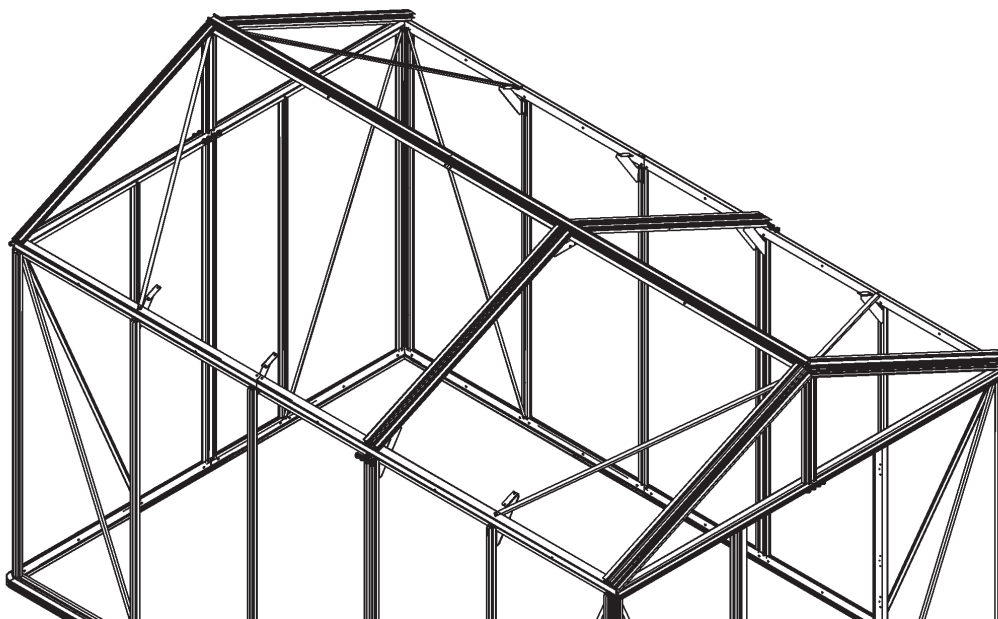
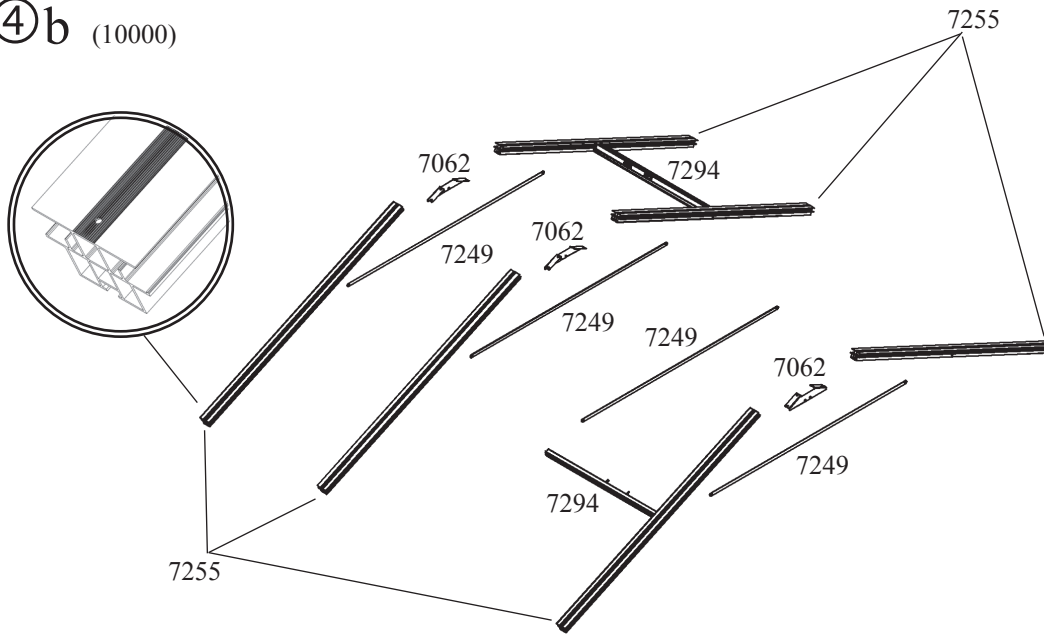

Model				
8100	10000	11900	13800	15700
1006				
8x	8x	12x	12x	12x
6056				
4x	4x	6x	6x	6x
7047				
2x	4x	4x	6x	8x
7048				
-	1x	2x	2x	2x
7052				
24x	36x	48x	60x	72x
7053				
24x	36x	48x	60x	72x
7054				
4x	4x	6x	6x	6x
7055				
4x	4x	6x	6x	6x
7062				
2x	3x	4x	5x	6x
7249				
3x	4x	5x	6x	7x
7255				
4x	6x	8x	10x	12x
7294				
2x	2x	3x	3x	3x

VM0009-Z2

TAGMELLEMPROFILER

BEMÆRK VENLIGST:

Til dette trin i opbygningsprocessen bør der være to eller tre personer. De får brug for en eller gerne to stiger.

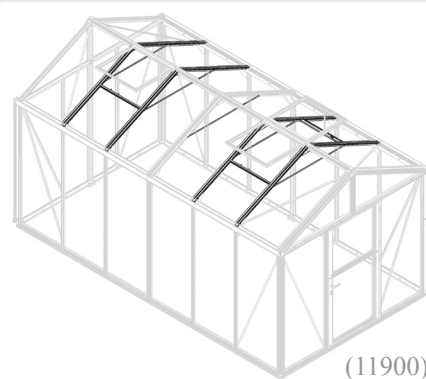

(11900)

Forbered tagmellemprofilerne 7255 ved at indføre 4 tombolte i hvert profilspor og fastgør dem løst mellem mellem tagryg (4b.1) og tagrem (4b.2) med møtrik 7053, se også ④ b. Vær opmærksom på, at det lille hul på ydersiden af 7255 er tættest på tagremmen.

Nu monteres rygningsbeslag 7062 (4b.2) og de allerede formonterede afstivere (4b.1) ved tagremmen.

Ventilationsvinduerne kan placeres valgfrit, dog ikke i ydersektionerne eller i to nabosektioner. Vinduernes placering afgøres ved at anbringe vinduets underkarm 7294 og den vandrette tagafstiver 7249 i de sektioner, hvor vinduerne ønskes placeret.

Monter de resterende tagafstivere 7249, se (4b.3), (4b.4).

Når vinduets underkarm 7294 er monteret kan der monteres to pløkker 6056 ved hjælp af skruer 1006.

Tagmellemprofiler

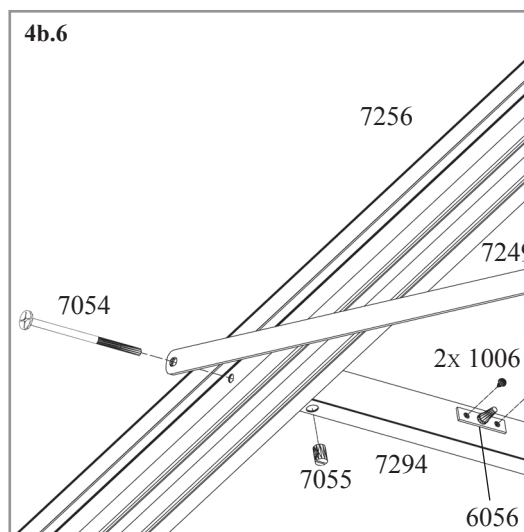
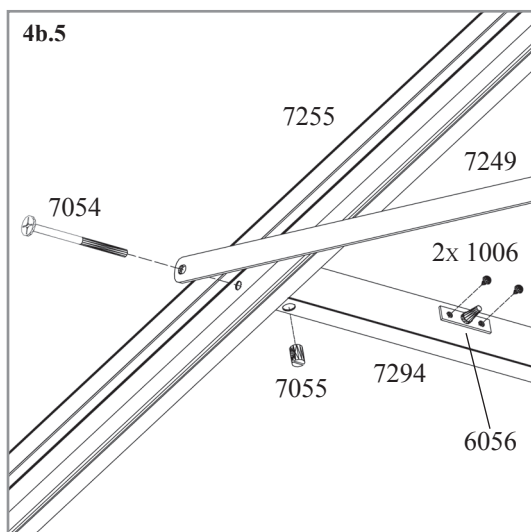
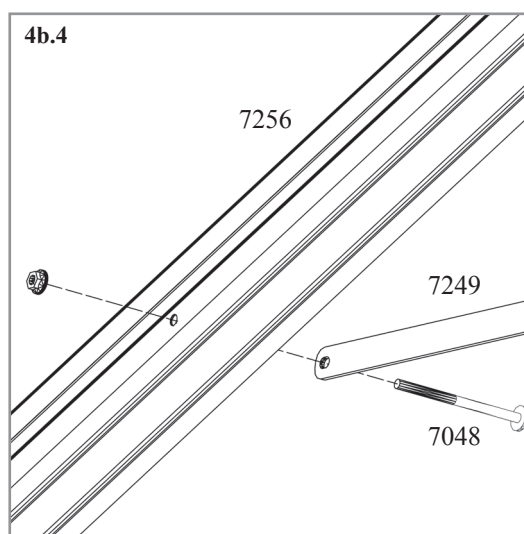
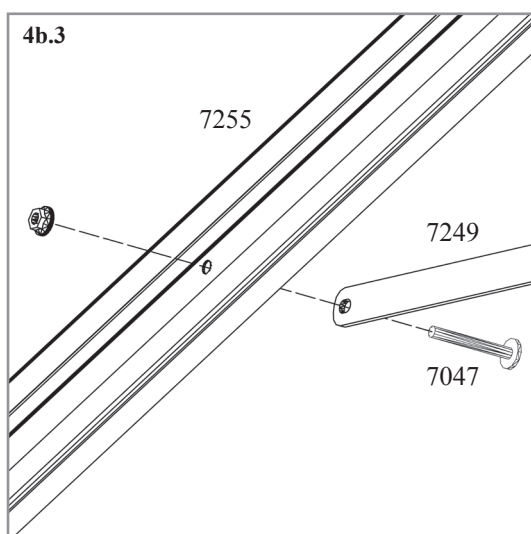

VM0009-Z2

⑤

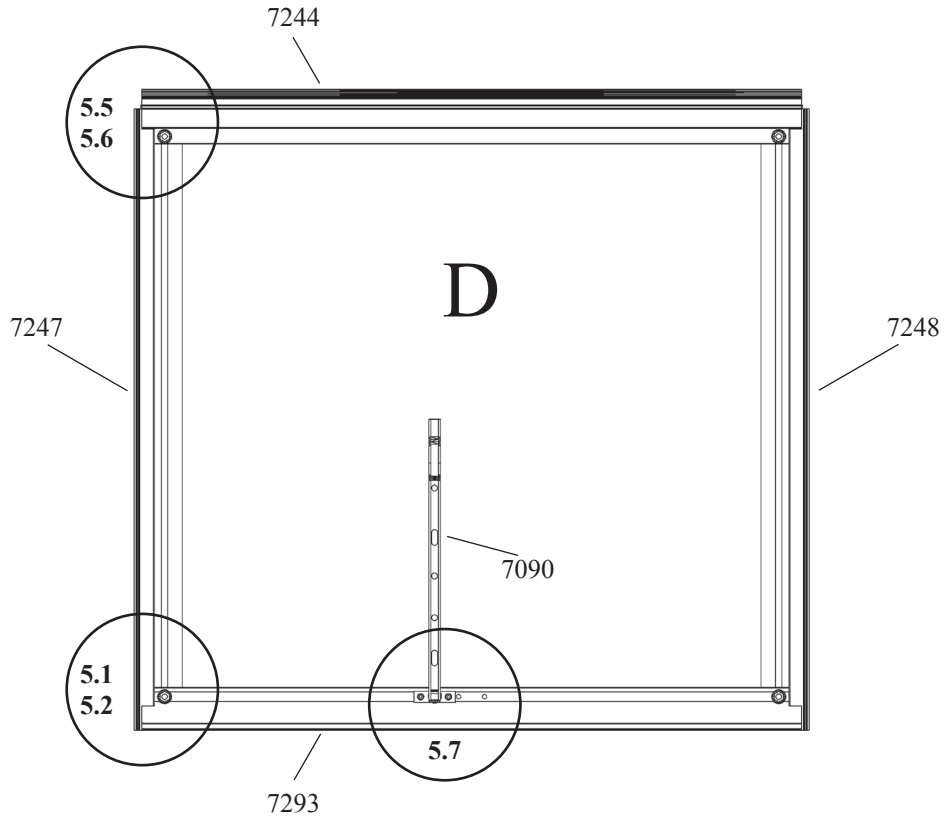

5.1	POLYCARBONAT				ANTAL / MODEL				
	10 MM		16 MM		8100	10000	11900	13800	15700
	KODE	MM	KODE	MM					
D	3695744	670 x 660	3695745	645 x 637	1x2	1x2	1x3	1x3	1x3

Model				
8100	10000	11900	13800	15700
2x	2x	3x	3x	3x
1006				
2x2	2x2	2x3	2x3	2x3
7052				
4x2	4x2	4x3	4x3	4x3
7053				
4x2	4x2	4x3	4x3	4x3
7090				
1x2	1x2	1x3	1x3	1x3
7244				
1x2	1x2	1x3	1x3	1x3
7247 (7291)				
1x2	1x2	1x3	1x3	1x3
7248 (7291)				
1x2	1x2	1x3	1x3	1x3
7293				
1x2	1x2	1x3	1x3	1x3

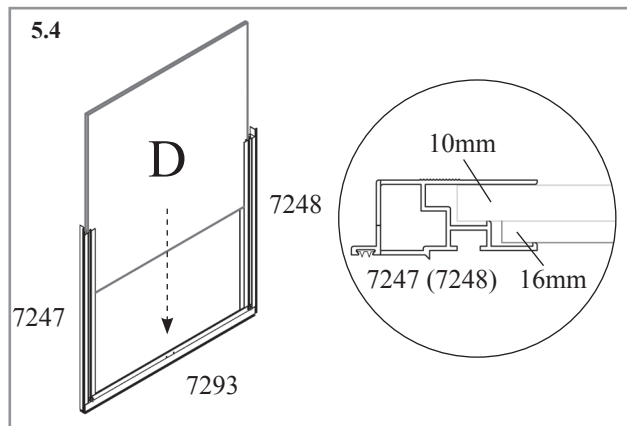
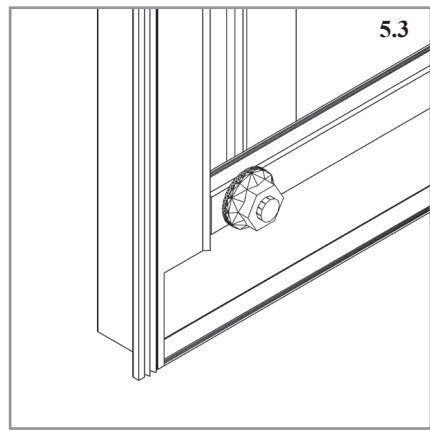
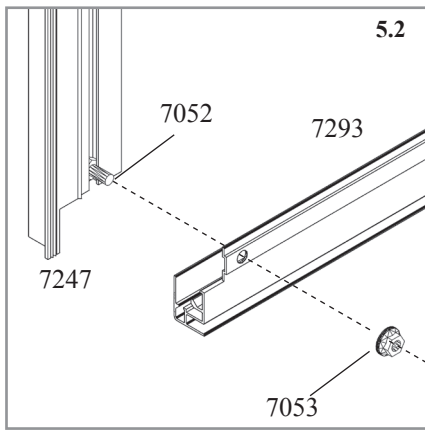

VENTILATIONSVINDUER

BEMÆRK VENLIGST:

Ved montering af ventilationsvinduet skal polycarbonatpladen isættes, inden tophængselsprofil 7244 monteres.

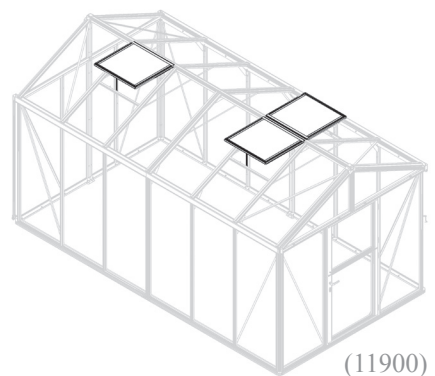

Spænd vinduets bundprofil 7293 sammen med de to sideprofiler 7247 og 7248 ved hjælp af bolt 7052 og møtrik 7053, se ⑤ (5.2), (5.3).

Før polycarbonatpladen jævnfør tabel (5.1) ind i profilerne som vist i 5.4.

Forbered vinduets topprofil 7244 ved løst i hver ende at montere bolt 7052 og møtrik 7053.

Før de løst monterede møtrikhoveder 7052 ind i sporet på profil 7247 og 7248 for derved at lukke rammen (5.5 – 5.6), samtidig med at det sikres, at polypladen sidder i sporet. Vær omhyggelig med at få vinduets hjørner i rette vinkler, inden møtrikkerne strammes – uden at overspænde.

Til sidst monteres udskyderstang 7090 på den nederste vinduesprofil 7293 (5.7) ved hjælp af skruer 1006.

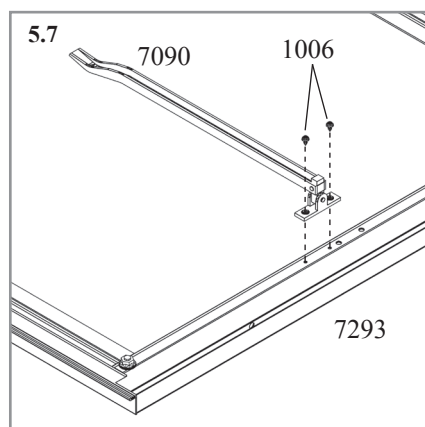
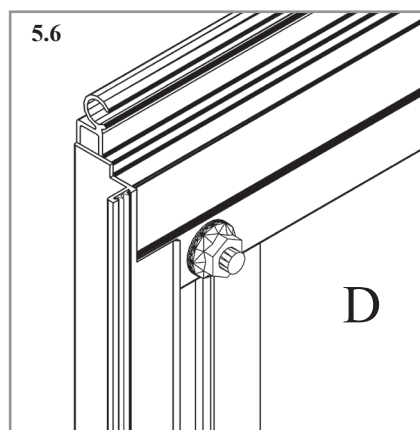
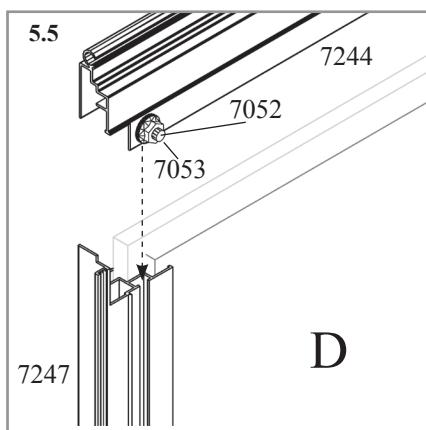

6a

⑥ a

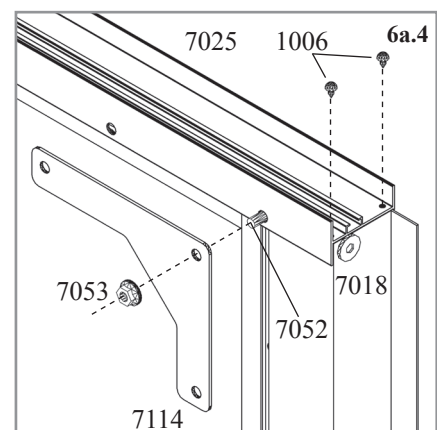
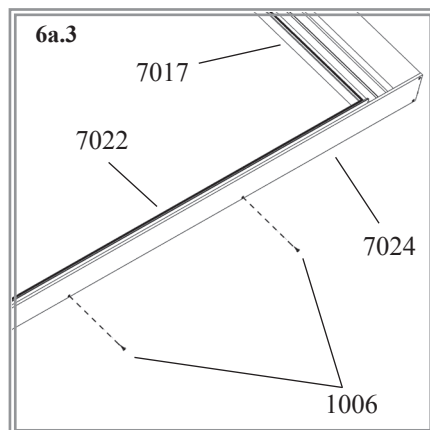
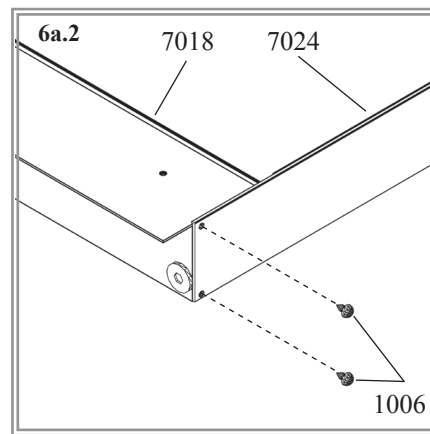
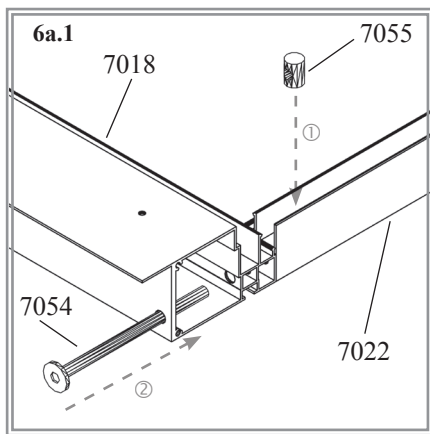
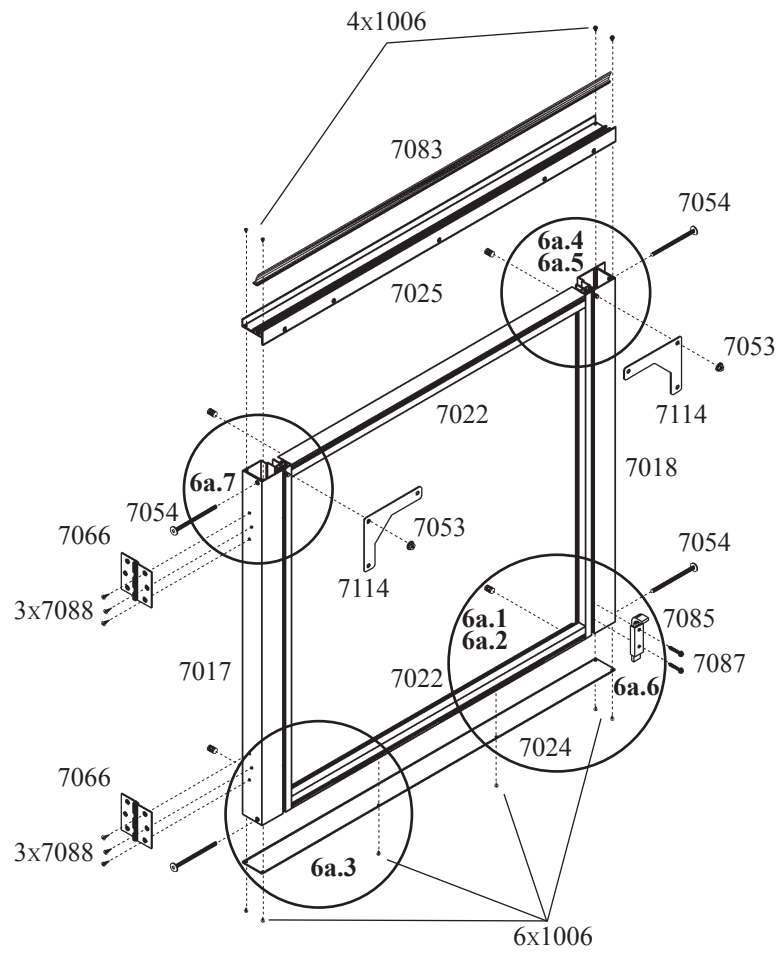

Alle modeller	
1006 10x	
7017 1x	
7018 1x	
7022 2x	
7024 1x	
7025 1x	
7052 2x	
7053 2x	
7054 4x	
7055 4x	
7066 2x	
7083 1x	
7085 1x	
7087 2x	
7088 6x	
7114 2x	

ØVERSTE DØRDEL

BEMÆRK VENLIGST:

Isætning af glas i dørene beskrives i afsnit 7c.

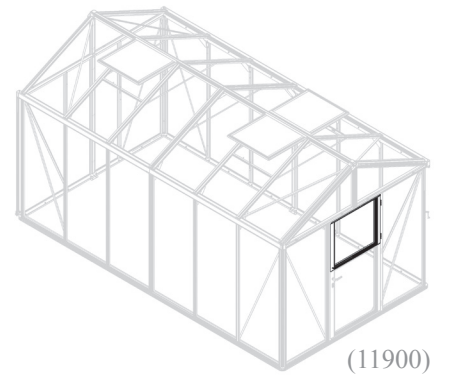

Sæt en tombolt 7052 med møtrik 7053 i profil 7017 og profil 7018.

Forbind sideprofilerne 7017 og 7018 med de vandrette profiler 7022 som vist i ©a.

Saml rammen til den øverste del af døren, der består af kode 7017, 7018 og 2 stk. 7022, ved hjælp af samleskrue 7054 og tværbøsning 7055 (6a.1) og (6a.2). Bemærk de forborede huller til montering af skudrigle 7085.

Monter afdækningsprofil 7024 fornedden (6a.3) og 7025 foroven med skruer 1006 og de tidligere monterede bolte 7052 og møtrikker 7053 (6a.4). Samtidig med montering af 7025 monteres også hjørnebeslag 7114. Tætningsliste 7083 føres ind i den øvre afdækningsprofil 7025 (6a.5). Monter skudriglen 7085 på den lodrette dørprofil 7018 (6a.6) ved hjælp af skruer 7087. Dørhængsler 7066 monteres på den lodrette dørprofil 7017 (6a.7) ved hjælp af skruer 7088.

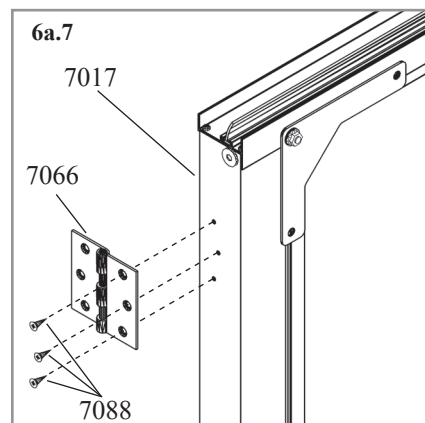
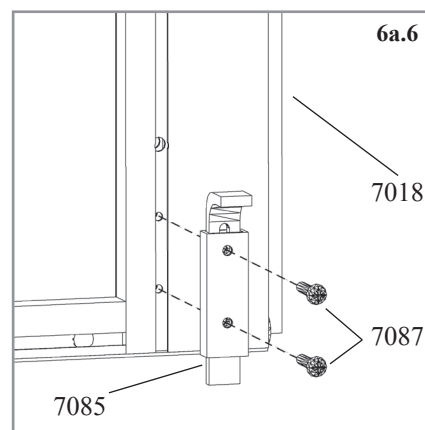
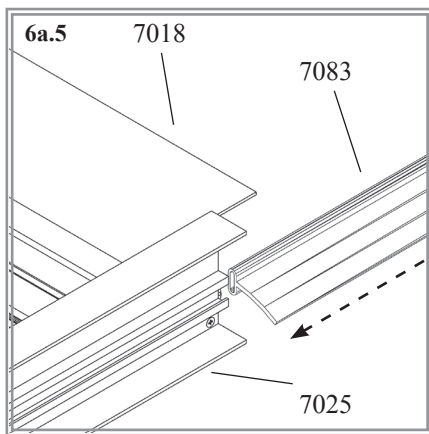

Øverste dørdeel

6b

⑥b

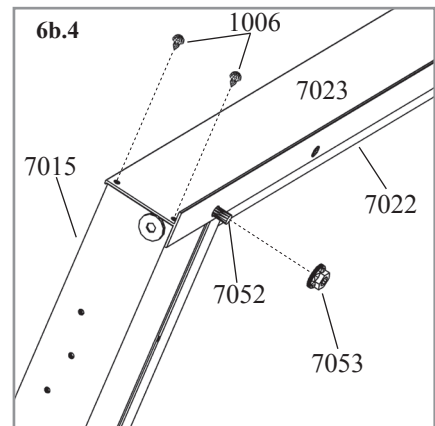
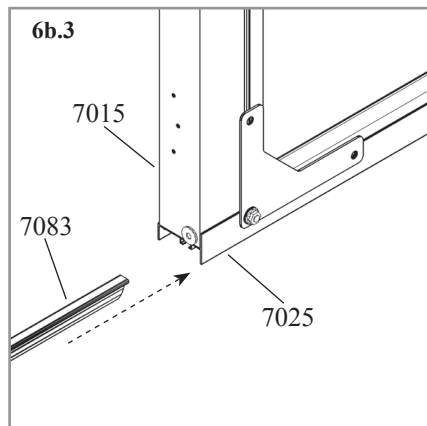
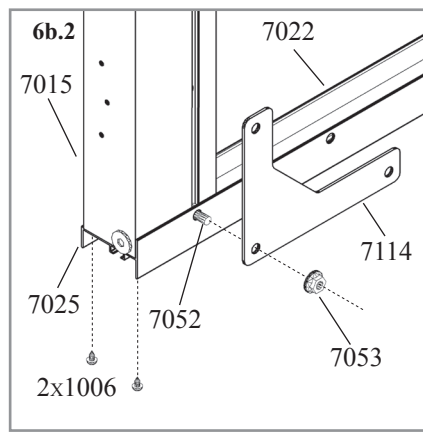
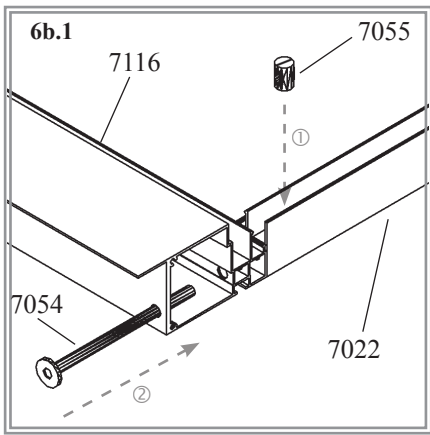
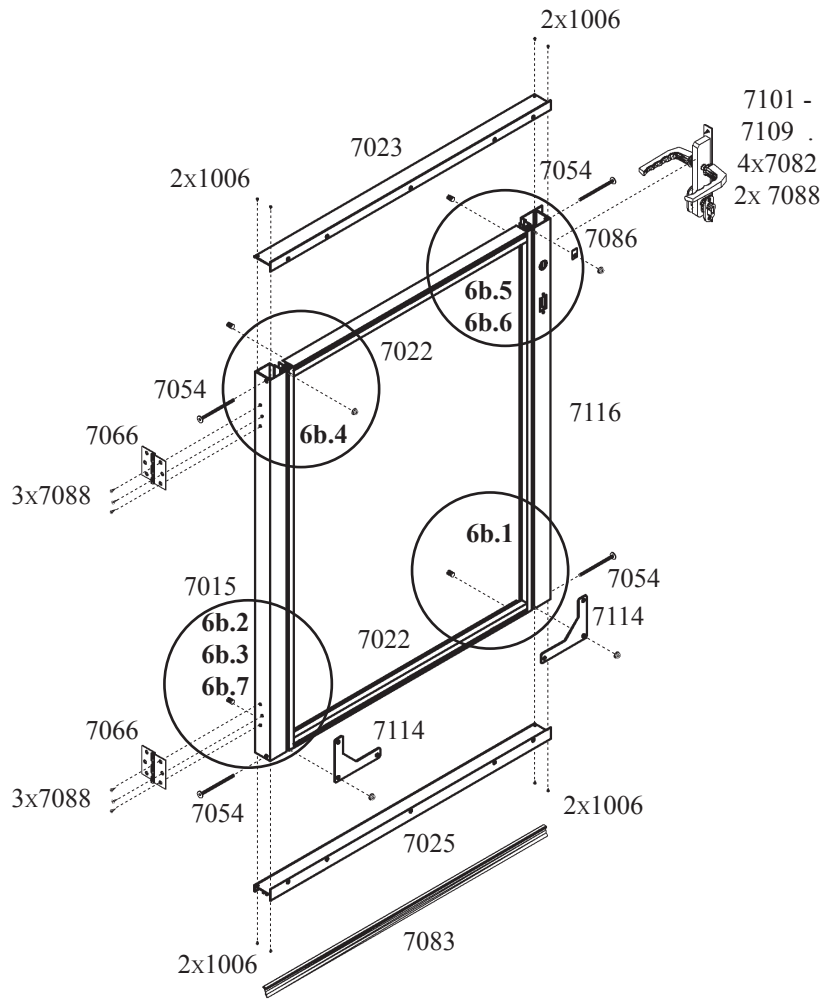

Alle modeller	
1006 8x	
7015 1x	
7022 2x	
7023 1x	
7025 1x	
7052 4x	
7053 4x	
7054 4x	
7055 4x	
7066 2x	
7082 4x	
7083 1x	
7086 1x	
7088 8x	
7101 1x	
7102 1x	
7103 2x	
7104 2x	
7106 2x	
7107 1x	
7108 2x	
7109 1x	
7114 2x	
7116 1x	

VM0009-Z2

NEDERSTE DØRDEL

BEMÆRK VENLIGST:

Isætning af glas i dørene beskrives i sektion 7c.

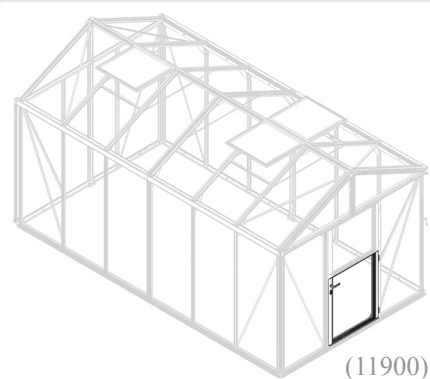

Monter to tombolte 7052 med møtrikker 7053 i hver af profilerne 7015 og 7116 (6b.2), (6b.4) og (6b5).

Som vist i 6b samles rammen til den nederste del af døren, der består af 7015, 7116 og 2 stk. 7022, ved hjælp af tværbøsning 7055 og samleskrue 7054, der føres gennem de forborede huller i 7022, (6b.1).







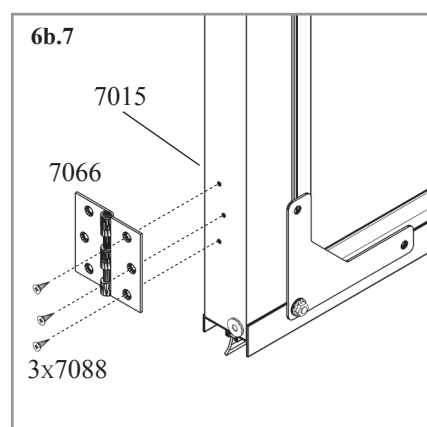
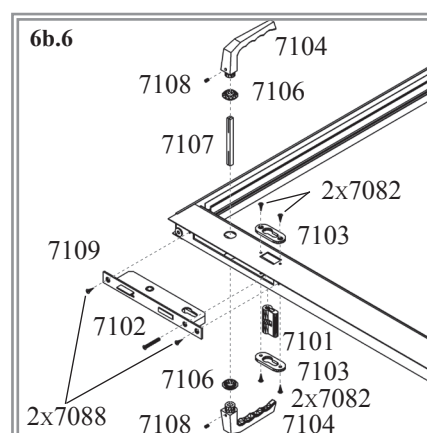
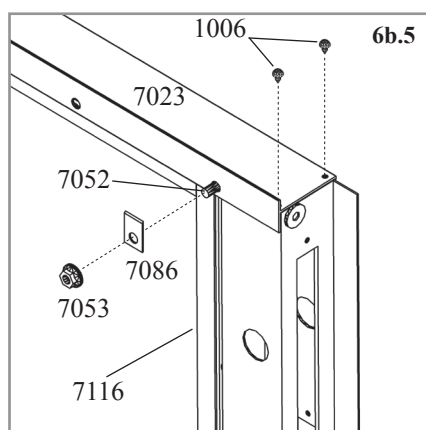

Monter afdækningsprofil 7025 forneden (6b.2) med 4 skruer 1006 og hjørnebeslag 7114. Tætningsliste 7083 føres ind i den nederste afdækningsprofil 7025 (6b.3).









Afdækningsprofil 7023 monteres foroven med 4 skruer 1006 og de tidligere monterede bolte 7052 og møtrikker 7053 (6b.4). I samme arbejdsgang monteres låseplade 7086 til 7023 ved hjælp af den formonterede bolt 7052 og møtrik 7053.

Dørlåsen 7101 – 7109 samles og fastspændes til 7116 ved hjælp af skruer 7082 & 7088 (6b.6).

Ved hjælp af skruer 7088 fastspændes hængslerne 7066 til den lodrette dørprofil 7015 (6b.7).



7.1	POLYCARBONAT						ANTAL / MODEL				
	6 MM (TAG 10MM)		10 MM		16 MM		8100	10000	11900	13800	15700
	KODE	MM	KODE	MM	KODE	MM					
A 	3695711	725 x 1790	3695712	725 x 1790	3695713	725 x 1790	12x	14x	16x	18x	20x
B 	3695726	725 x 1368	3695726	725 x 1368	3695727	710 x 1368	6x	8x	9x	11x	13x
C 	3695736	725 x 699	3695736	725 x 699	3695737	710 x 691	2x	2x	3x	3x	3x
D 	3695744	670 x 660	3695744	670 x 660	3695745	645 x 637	2x	2x	3x	3x	3x
E 	3695751	725 x 966	3695752	725 x 966	3695753	725 x 966	1x	1x	1x	1x	1x
F 	3695761	725 x 683	3695762	725 x 683	3695763	725 x 683	1x	1x	1x	1x	1x
G 	3695771	1190x567/15	3695772	1190x567/15	3695773	1190x567/15	2x	2x	2x	2x	2x
H 	3695781	1190x567/15	3695782	1190x567/15	3695783	1190x567/15	2x	2x	2x	2x	2x
J 	3695791	435 x 1790	3695792	435 x 1790	3695793	435 x 1790	2x	2x	2x	2x	2x
TOTAL							30x	34x	39x	43x	47x

7.2	GLAS / POLYCARBONAT		ANTAL / MODEL				
	4 MM / 10MM		8100	10000	11900	13800	15700
	KODE	MM					
A 	367801	725 x 1790	12x	14x	16x	18x	20x
B 	3695726	725 x 1368 x 10	6x	8x	9x	11x	13x
C 	3695736	725 x 699 x 10	2x	2x	3x	3x	3x
D 	3695744	670 x 660 x 10	2x	2x	3x	3x	3x
E 	367805	725 x 966	1x	1x	1x	1x	1x
F 	367806	725 x 683	1x	1x	1x	1x	1x
G 	367807	1190x567/15	2x	2x	2x	2x	2x
H 	367808	1190x567/15	2x	2x	2x	2x	2x
J 	367809	435 x 1790	2x	2x	2x	2x	2x
TOTAL			30x	34x	39x	43x	47x

GLASPLAN

BEMÆRK VENLIGST:

Til dette trin i opbygningsprocessen bør der være 2 personer.

Ved isætning af glas og polycarbonat bør anvendes arbejds-handsker, ligesom vi anbefaler at anvende beskyttelsesbriller, sikkerhedssko og sikkerhedshjelm!

Bemærk den foreskrevne rækkefølge til isætning af glas: 7a – 7b og 7c som vist.

Den udvendige side af polycarbonatpladerne er forsynet med en plastfolie eller mærket på anden vis.

Start med at sortere glas og polycarbonatplader efter modeltype i henhold til oversigten i tabel (7.1) eller 7.2, inden montagen påbegyndes.



Den UV-beskyttede side af polycarbonatpladerne er påsat en tynd plastic-folie, eller der er trykt en tekst ved pladekanterne. Denne side SKAL vende udad. Fjern først folien, når pladerne er monteret, da der ellers ikke er synlig forskel på den udvendige og indvendige side af pladerne.

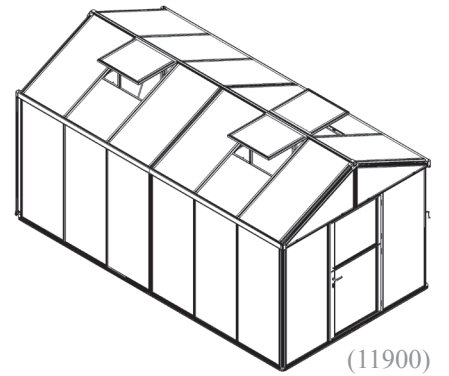

Glasplan

Model				
8100	10000	11900	13800	15700
A				
12x	14x	16x	18x	20x
B				
6x	8x	9x	11x	13x
C				
2x	2x	3x	3x	3x
E				
1x	1x	1x	1x	1x
F				
1x	1x	1x	1x	1x
G				
2x	2x	2x	2x	2x
H				
2x	2x	2x	2x	2x
J				
2x	2x	2x	2x	2x

(8100)

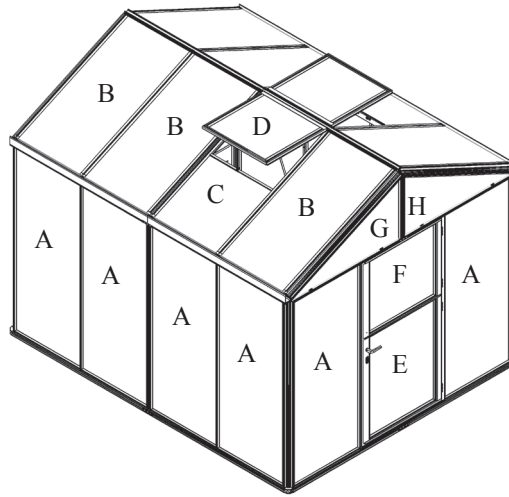

(10000)

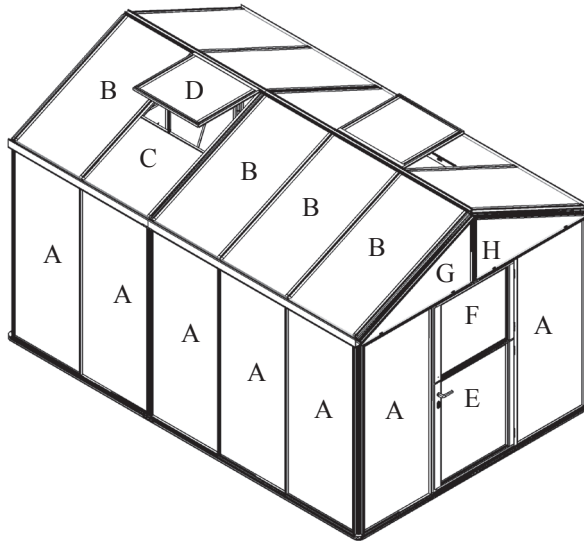

(11900)

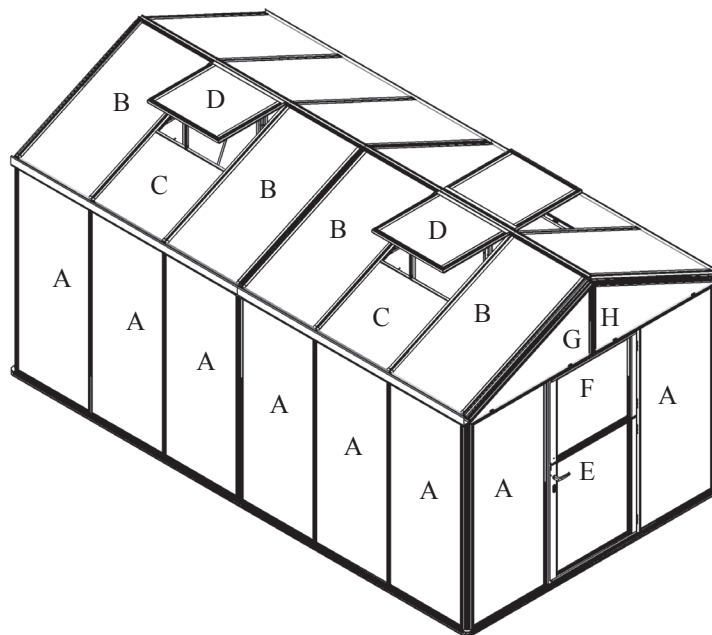

(13800)

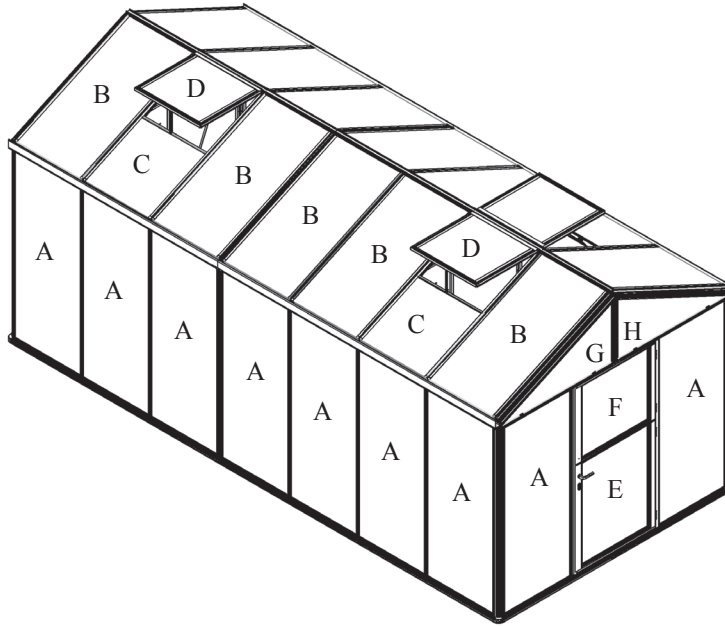

(15700)

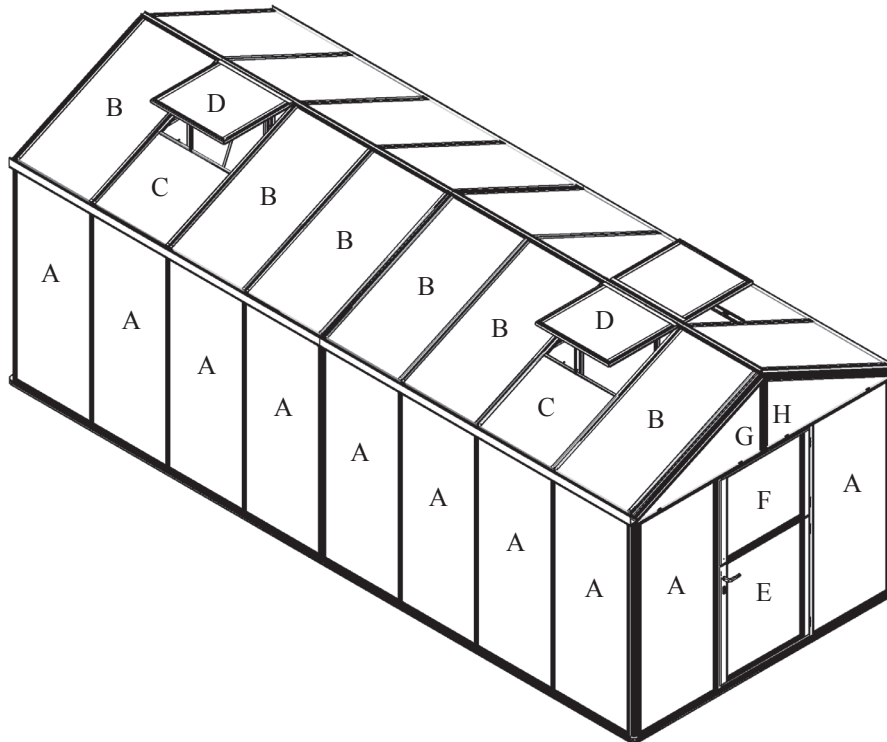

Baggavl – alle modeller

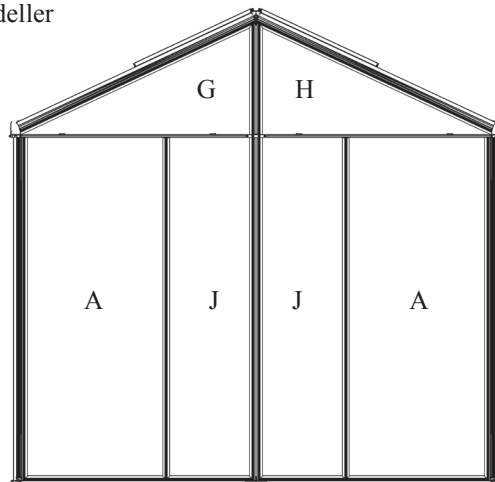

7a

Model				
8100	10000	11900	13800	15700
7052				
8x	10x	12x	14x	16x
7053				
8x	10x	12x	14x	16x
7061				
2x	2x	2x	2x	2x
7064				
2x	2x	2x	2x	2x
7080				
8x	8x	8x	8x	8x
7213				
4x	2x	-	-	-
7214				
-	2x	4x	2x	-
7215				
-	-	-	2x	4x
7240				
2x	2x	2x	2x	2x
7292				
2x	2x	2x	2x	2x
7296				
8x	10x	12x	14x	16x
7297				
8x	10x	12x	14x	16x
7298*				
14x	18x	21x	25x	29x
7299*				
14x	18x	21x	25x	29x
7342				
4x	4x	4x	4x	4x
7343				
4x	6x	8x	10x	12x
7349				
46x	58x	68x	80x	92x
VM0009-Z2				

(10000)

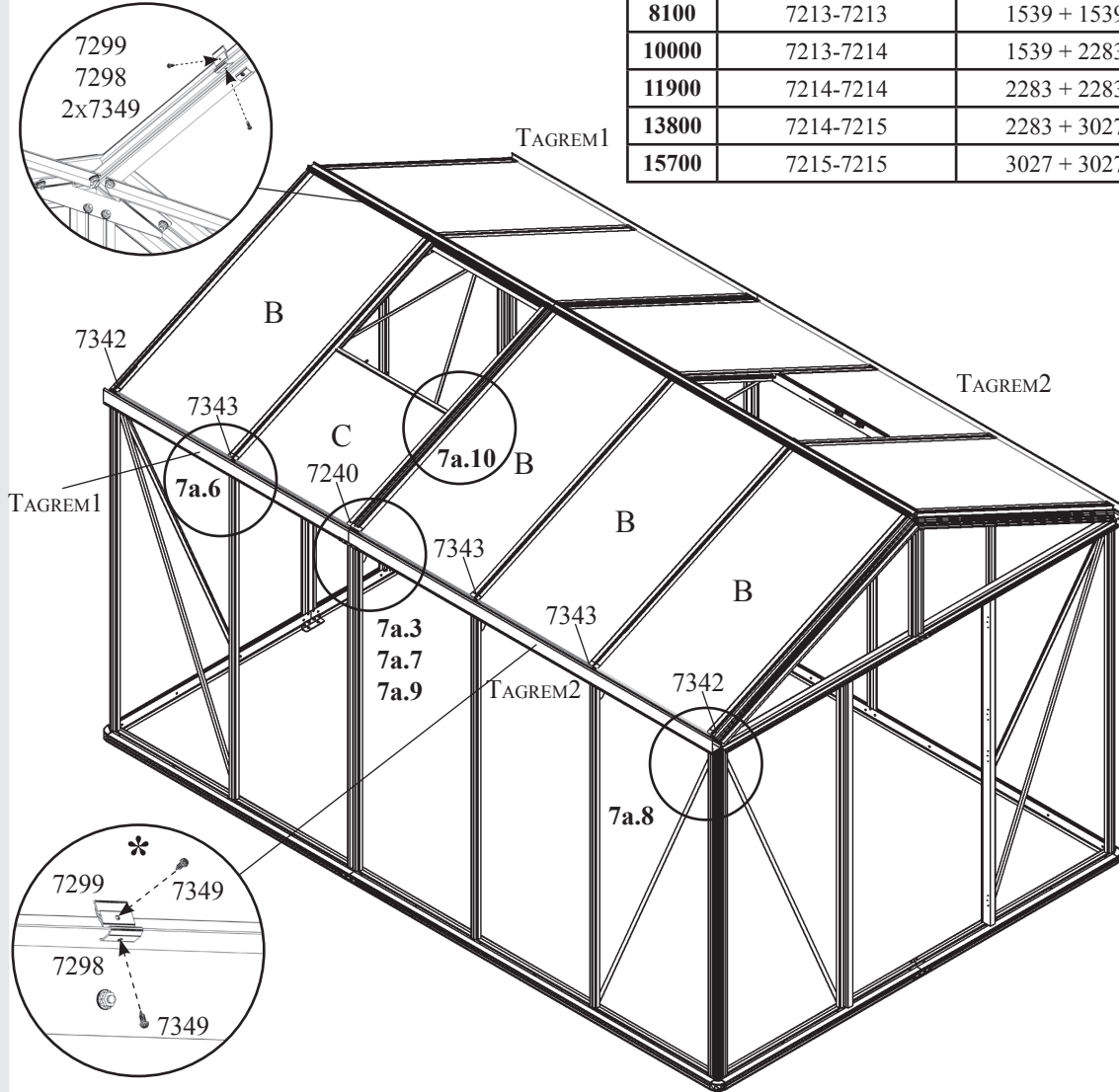

7a.1	TAGREM 1 – TAGREM 2	LÆNGDE
8100	7213-7213	1539 + 1539 mm
10000	7213-7214	1539 + 2283 mm
11900	7214-7214	2283 + 2283 mm
13800	7214-7215	2283 + 3027 mm
15700	7215-7215	3027 + 3027 mm

7a.2	POLYCARBONAT				ANTAL / MODEL				
	10 MM		16 MM		8100	10000	11900	13800	15700
	KODE	MM	KODE	MM					
B	3695726	725 x 1368	3695727	710 x 1368	6x	8x	9x	11x	13x
C	3695736	725 x 699	3695737	710 x 691	2x	2x	3x	3x	3x

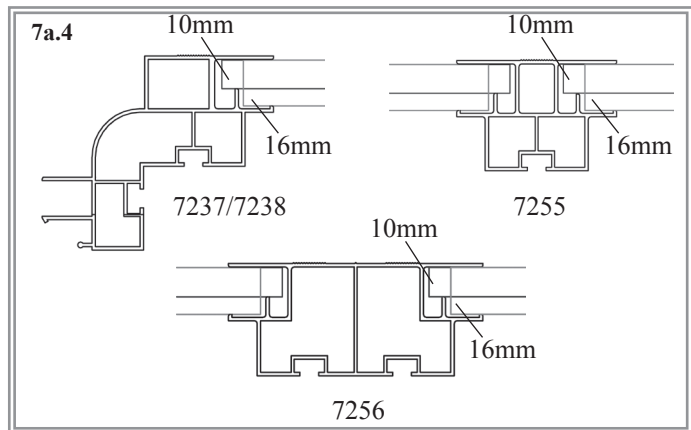
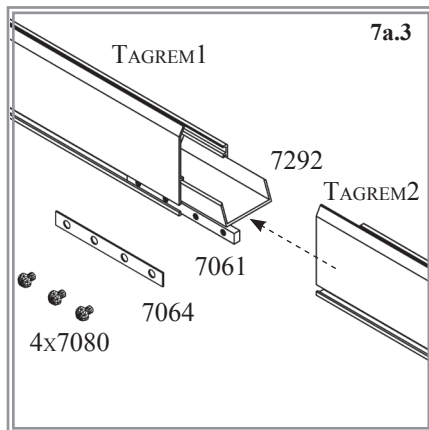

ISÆTNING AF GLAS I TAGET / TAGRENDE (TAGREM)

BEMÆRK VENLIGST:

Til dette trin i opbygningsprocessen bør der være 2 personer – og meget gerne 3.

Ved isætning af glas og polycarbonat bør anvendes arbejdshandsker, ligesom vi anbefaler at anvende beskyttelsesbriller, sikkerhedssko og sikkerhedshjelm!

Den udvendige side af polycarbonatpladerne er forsynet med en plastfolie eller mærket på anden vis.

Klargør tagrenderne til slutmontage ved at forbinde tagrendeprofilerne i henhold til tabel (7a.1) med samlebeslagene 7061, laskeplade 7064 og bolte 7080 (7a.3). Kontroller, at plasticforbinder 7292 sidder centralt i forhold til samlingen.

Skub polycarbonatpladerne på plads i tagprofilerne som vist i (7a.4) og (7a.5), bemærk i (7a.4), at der anvendes forskellige spor til 10 mm og 16 mm polycarbonatplader.

Når to naboplader er på plads monteres tagpladestop 7240, 7342 eller 7343 i tagprofilerne ved at montere selvskærende skruer 7349 i de forborede huller (7a.6). Tagpladerne skal glide ned og have anslag mod disse tagpladestop.

Anbring afstandsstykke 7296 på den indvendige side af kanten af tagremmen (7a.7). Hvis der anvendes 10 mm polycarbonatplader skal afstandsstykke 7297 anbringes i rillen på 7296 således, at den støder an mod polycarbonatpladen. Afstandsstykket/stykkerne fastgøres ved hjælp af skruer 7349, der fastgøres i de forborede huller (7a.7) og (7a.9).

Ved 16 mm polycarbonatplader er det ikke nødvendigt at anvende afstandsstykke 7294 (7a.9b).

I tagsektionerne med ventilationsvinduer isættes polycarbonatpladerne C ved at lade den glide i sporet i profil 7294 (7a.10).

Læg en streng af neutral silikone i hele den forreste tagrems længde (7201 – 7206), (7a.8).

Til sidst vippes hele tagremmen/tagrenden ned på plads (7a.8) således at den støder an mod sideprofilerne. Fastspænd tagremmen/tagrenden ved hjælp af bolte 7052, der monteres udvendigt fra og møtrikker 7053, der monteres fra indvendig side (7a.9).

** NB! : Kondensdannelse kan ikke helt undgås i et drivhus med polycarbonat, men kondensdannelsen kan reduceres ved at udskifte kode nr. (7296 / 7297) med kode nr. (7298 / 7299). Dette vil forøge luftcirkulationen og dermed reducere kondensdannelse. Ved hjælp af skrue (7349) anbringes en (7298 / 7299) i midten af hver tagplade ned mod tagkanten.*

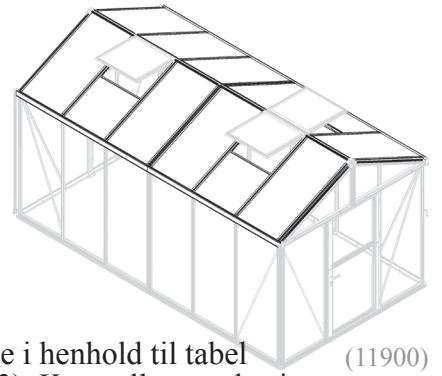

(11900)

Isætning af glas i taget / tagrende (tagrem)

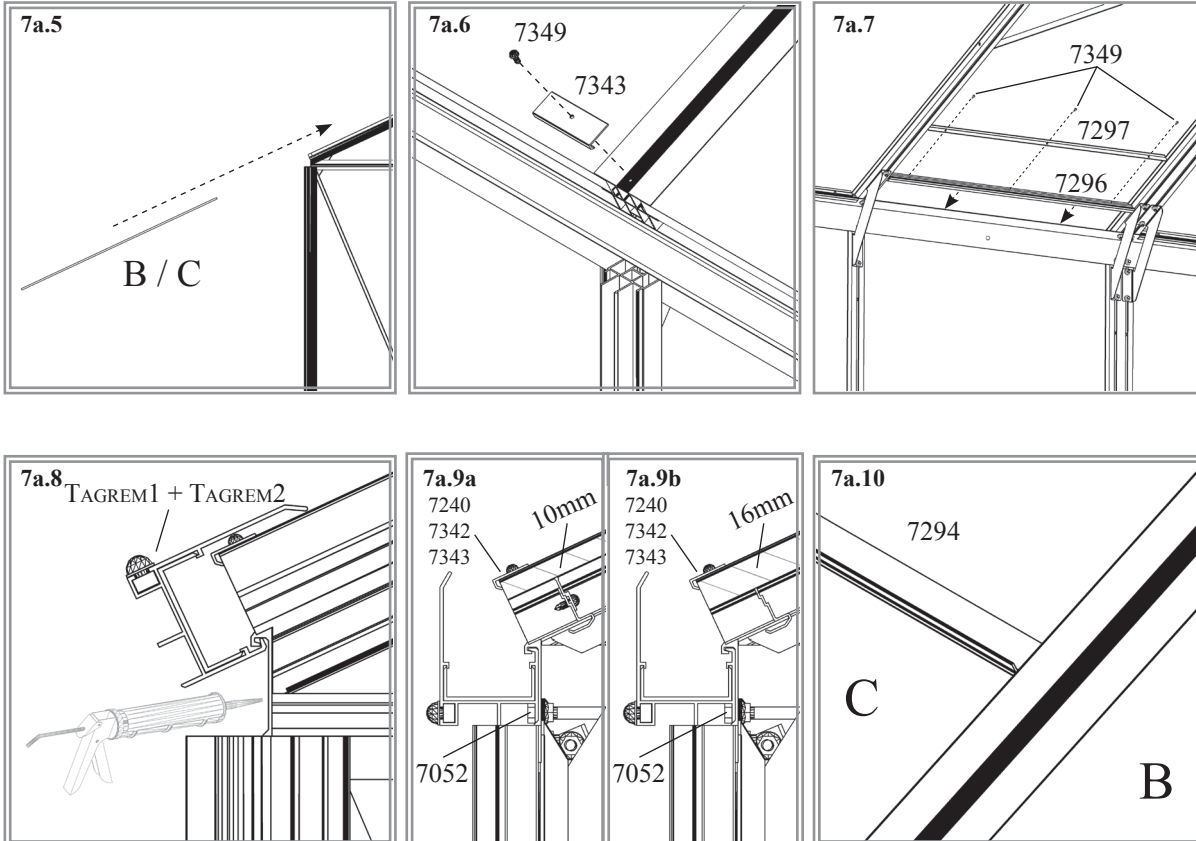

VM0009-Z2

7b

(10000)

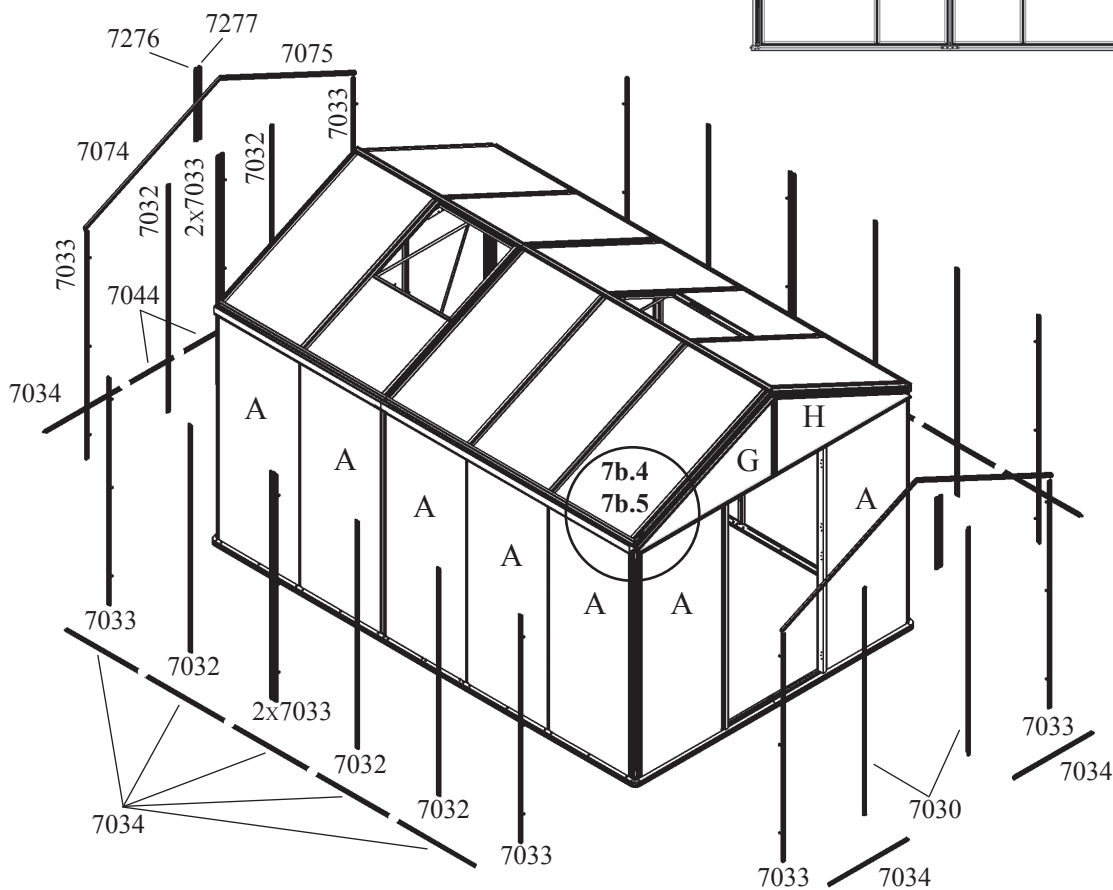
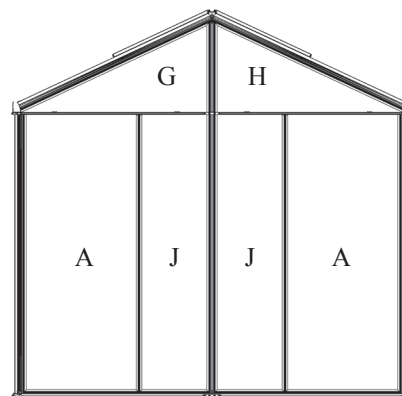
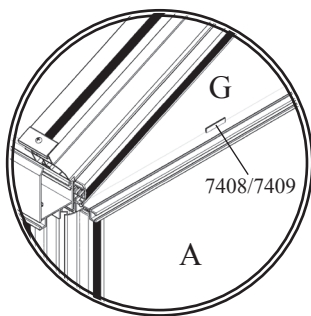

Model				
8100	10000	11900	13800	15700
6090				
1x	1x	1x	1x	1x
7030				
2x	2x	2x	2x	2x
7032				
6x	8x	10x	12x	14x
7033				
14x	14x	14x	14x	14x
7034				
12x	14x	16x	18x	20x
7044				
2x	2x	2x	2x	2x
7050				
126x	138x	150x	162x	174x
7053				
126x	138x	150x	162x	174x
7074				
2x	2x	2x	2x	2x
7075				
2x	2x	2x	2x	2x
7276				
2x	2x	2x	2x	2x
7277				
2x	2x	2x	2x	2x
7406				
14x	16x	18x	20x	22x
7407				
14x	16x	18x	20x	22x
7408				
8x	8x	8x	8x	8x
7409				
8x	8x	8x	8x	8x

7b.1	GLAS	POLYCARBONAT				MM	ANTAL / MODEL				
		4 MM	6 MM	10 MM	16 MM		8100	10000	11900	13800	15700
		KODE	KODE	KODE	KODE						
A		367801	3695711	3695712	3695713	725 x 1790	12x	14x	16x	18x	20x
G		367807	3695771	3695772	3695773	1190x567/15	2x	2x	2x	2x	2x
H		367808	3695781	3695782	3695783	1190x567/15	2x	2x	2x	2x	2x
J		367809	3695791	3695792	3695793	435 x 1790	2x	2x	2x	2x	2x

ISÆTNING AF GLAS I SIDERNE

BEMÆRK VENLIGST:

Til dette trin i opbygningsprocessen bør der være 2 personer – og meget gerne 3.

De bør altid bruge arbejdshandsker, når De arbejder med polycarbonatplader eller glas. Ved isætning af glas bør De også anvende beskyttelsesbriller, sikkerhedssko og hovedbeskyttelse (sikkerhedshjelm). Itugået glas udgør en sikkerhedsrisiko og bør bortskaffes med forsigtighed.

Bemærk den foreskrevne rækkefølge til isætning af glas.

Den udvendige side af polycarbonatpladerne er forsynet med en plastfolie eller mærket på anden vis.

Ved isætning af 4 mm glas skal der anvendes glasliste 6090, der monteres på aluminiumsprofilerne før glasset sættes. Ved isætning af polycarbonatplader er det ikke nødvendigt at anvende glasliste 6090.

Ved isætning af 4 mm glas eller 16 mm polycarbonat er det ikke nødvendigt at anvende afstandsstykker 7406 – 7409.

Ved isætning af 4 mm glas skal glasliste 6090 anvendes. 6090 monteres på aluminiumsprofilerne før glasset sættes som vist i (7b.2).

Fastgørelseslisterne/dæklisterne kan anvendes til forskellige glas/pladetykkelser.

For at muliggøre dette, skal hovederne på bolte 7050 indføres i forskellige positioner i afdækningslisterne (7b.2). Klargør afdækningslisterne med tre bolte 7050 hver, som vist på ill. (7b.3). Ved dæklister 7044 skal der kun anvendes 2 bolte 7050.

Anbring et afstandsstykke (6 mm 7406 / 10 mm 7407) i midten / toppen af rude A eller J (7b.4). Anbring hver glas A eller J i rammen og monter de lodrette dæklister løst med møtrik 7053.

Løft glasset ca. 15 mm for at kunne forbinde dæklister 7034 og 7044 løst under ruden.

Anbring to afstandsstykker (6 mm 7408 / 10 mm 7409) på hver 7134 (7b.5).

Anbring rude G og H i afstandsstykkerne og forbind løst dæklister 7074, 7075, 7276 og 7277.

Kontroller, at drivhuset er i lod og vater overalt inden boltene og møtrikker spændes til.

Pas på ikke at overspænde bolte og møtrikker!



TIP: De lodrette dæklister monteres lettest ved at starte med at isætte den nederste bolt i hullet, derefter den midterste og endelig den øverste. Sørg for, at dæklisten fortsat rører ved bundlisten.

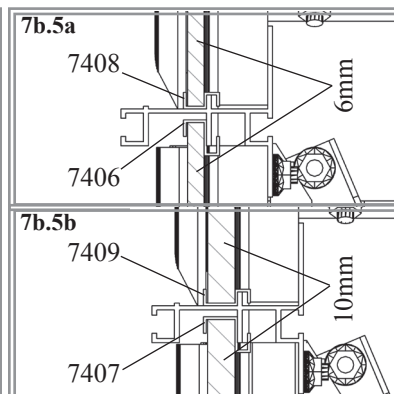
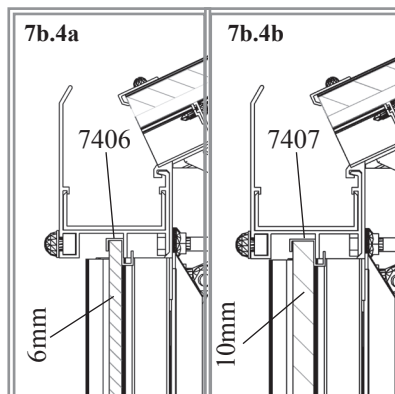
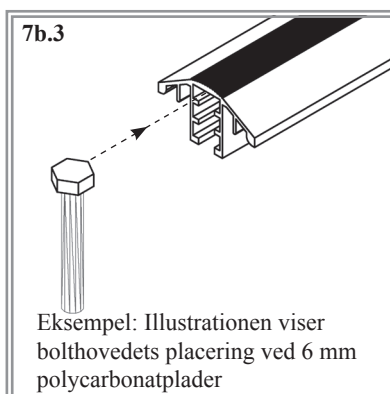
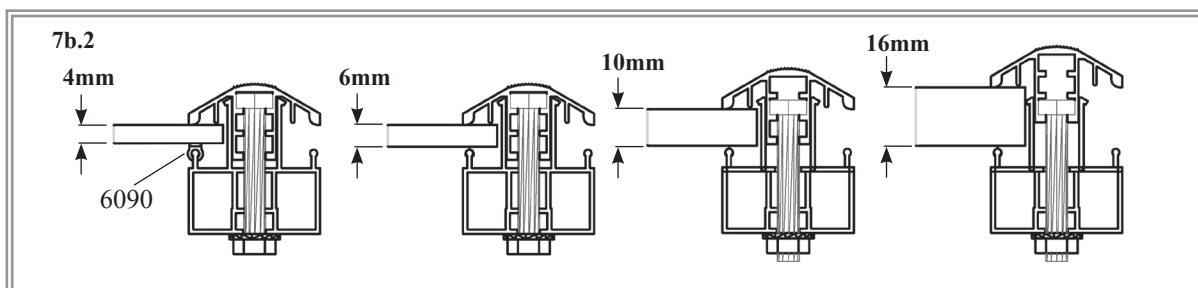
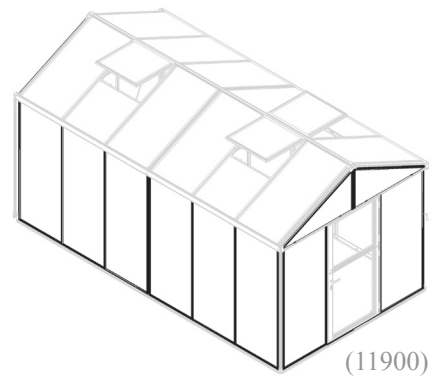

7c

Alle modeller	
6090 1x	
7031 2x	
7034 4x	
7035 2x	
7053 22x	
7058 22x	
E 1x	
F 1x	

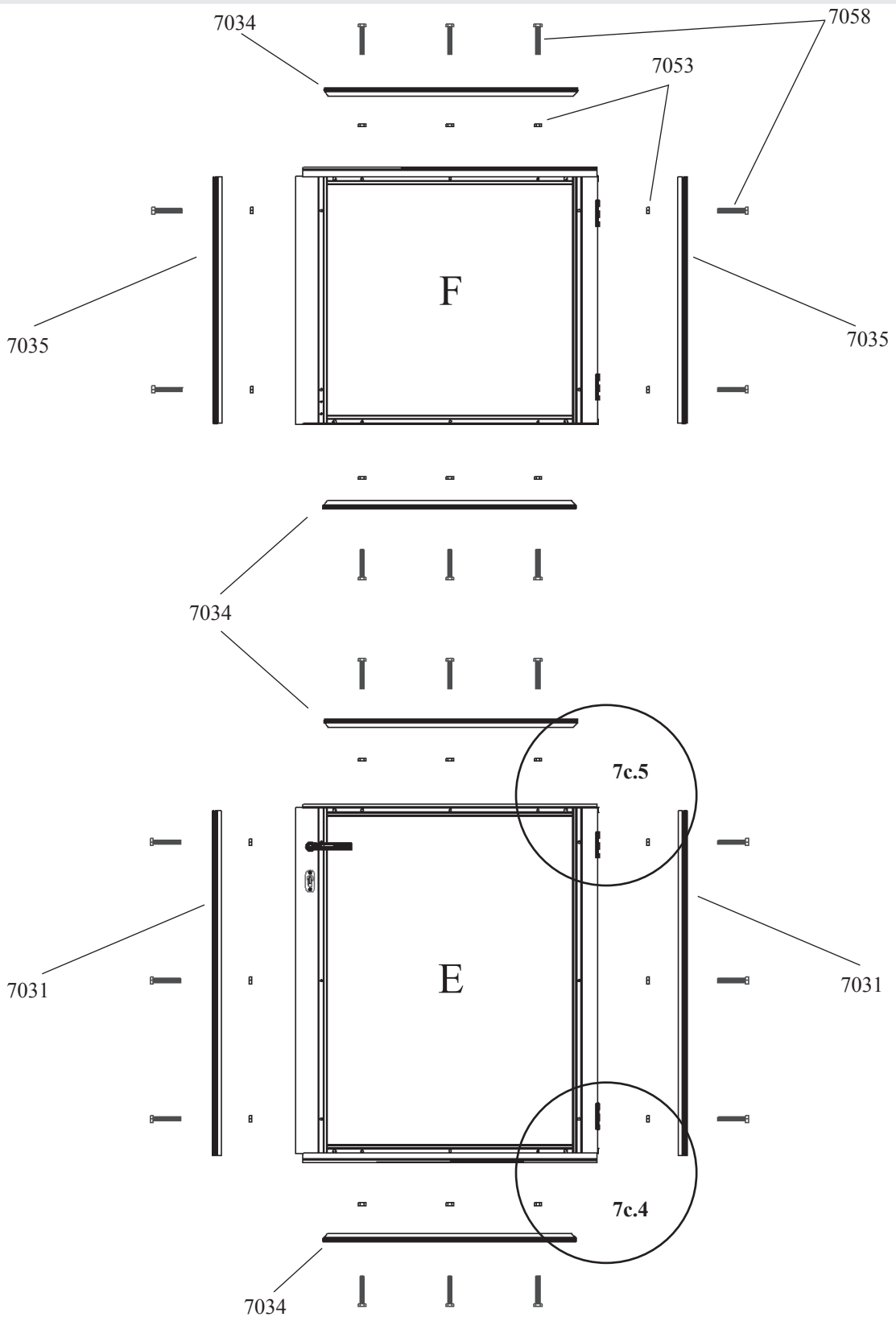

7c.1	GLAS	POLYCARBONAT				ANTAL / MODEL				
	4 MM	6 MM	10 MM	16 MM	MM	8100	10000	11900	13800	15700
	KODE	KODE	KODE	KODE		8100	10000	11900	13800	15700
E	367805	3695751	3695752	3695753	725 x 966	1x	1x	1x	1x	1x
F	367806	3695761	3695762	3695763	725 x 683	1x	1x	1x	1x	1x

VM0009-Z2

ISÆTNING AF GLAS I DØR

BEMÆRK VENLIGST:

De bør altid bruge arbejdshandsker, når De arbejder med polycarbonatplader eller glas. Ved isætning af glas bør De også anvende beskyttelsesbriller, sikkerhedssko og hovedbeskyttelse (sikkerhedshjelm). Itugået glas udgør en sikkerhedsrisiko og bør bortskaffes med forsigtighed.

Bemærk den foreskrevne rækkefølge til isætning af glas.

Den udvendige side af polycarbonatpladerne er forsynet med en plastfolie eller mærket på anden vis.

Ved isætning af 4 mm glas skal glasliste 6090 først monteres på profilerne som vist i (7c.2 detalje 1).

Ved isætning af polycarbonatplader anvendes glaslisten ikke.

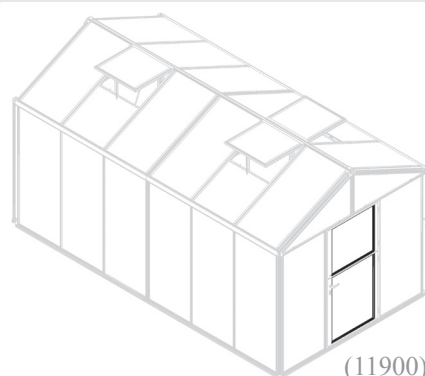

Fastgørelseslisterne/dæklisterne kan anvendes til forskellige glas/pladetykkelser. For at muliggøre dette, skal bolte 7058 indføres i forskellige positioner i afdækningslisterne (7c.2). Klarlæg afdækningslisterne med bolte 7058 som vist på ill. (7c.3).

Anbring glassene / polycarbonatpladerne i aluminiumsrammen.

Placér dæklisterne og spænd dem løst fast med møtrik 7053.

Kontroller, at dørene er i vinkel, før alle bolte og møtrikker spændes til **uden at overspænde**.

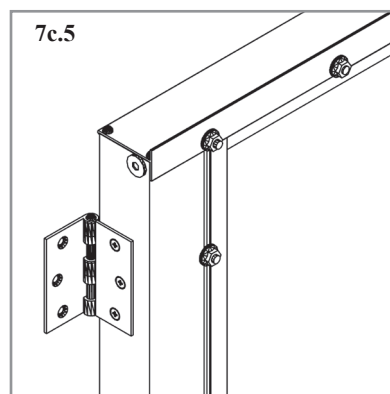
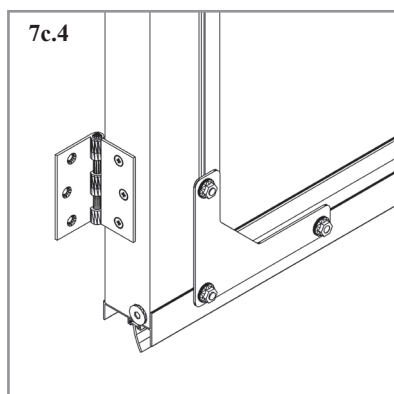
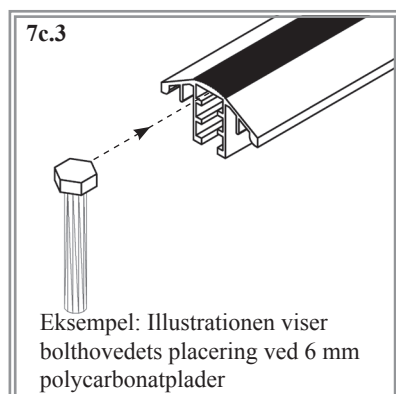
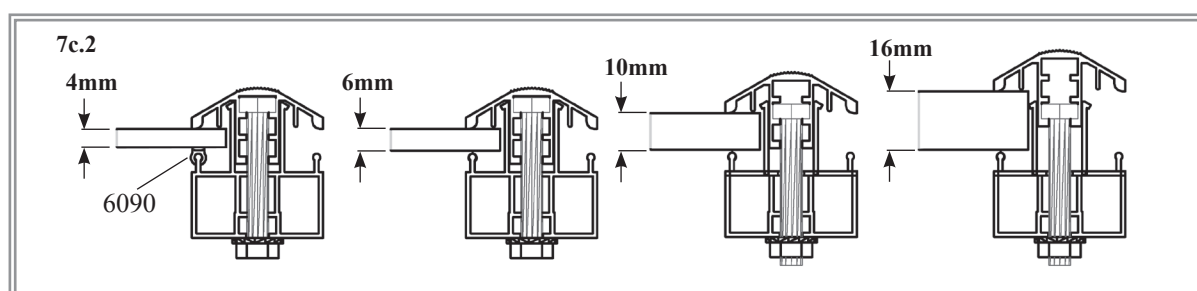

(10000)

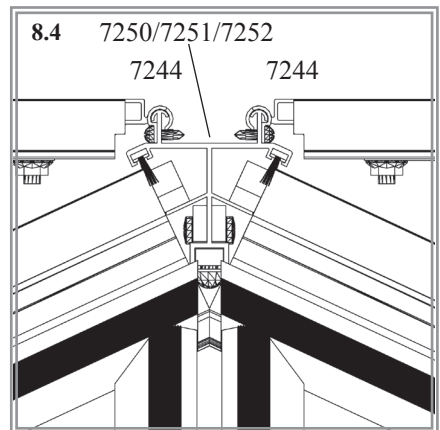
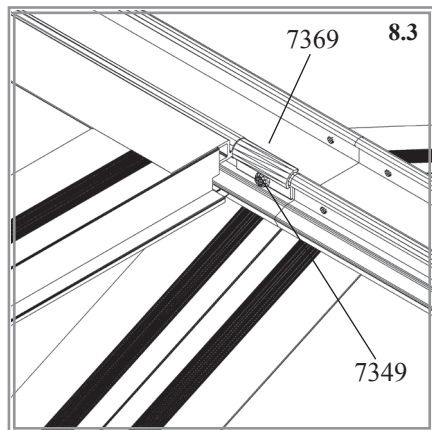
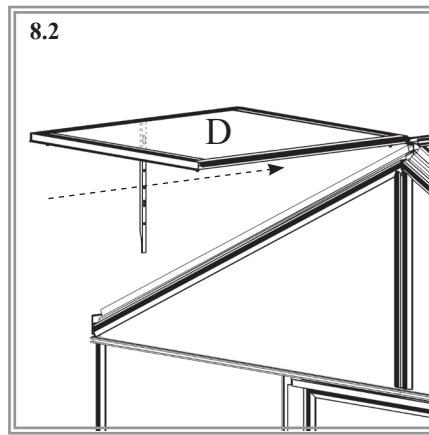
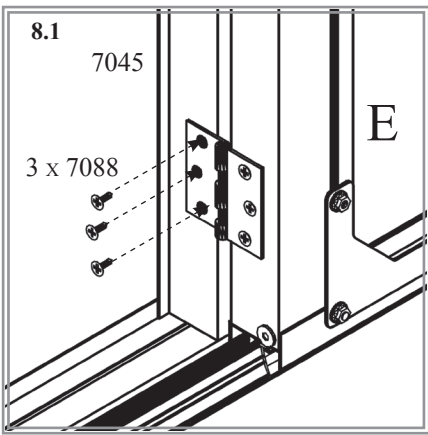
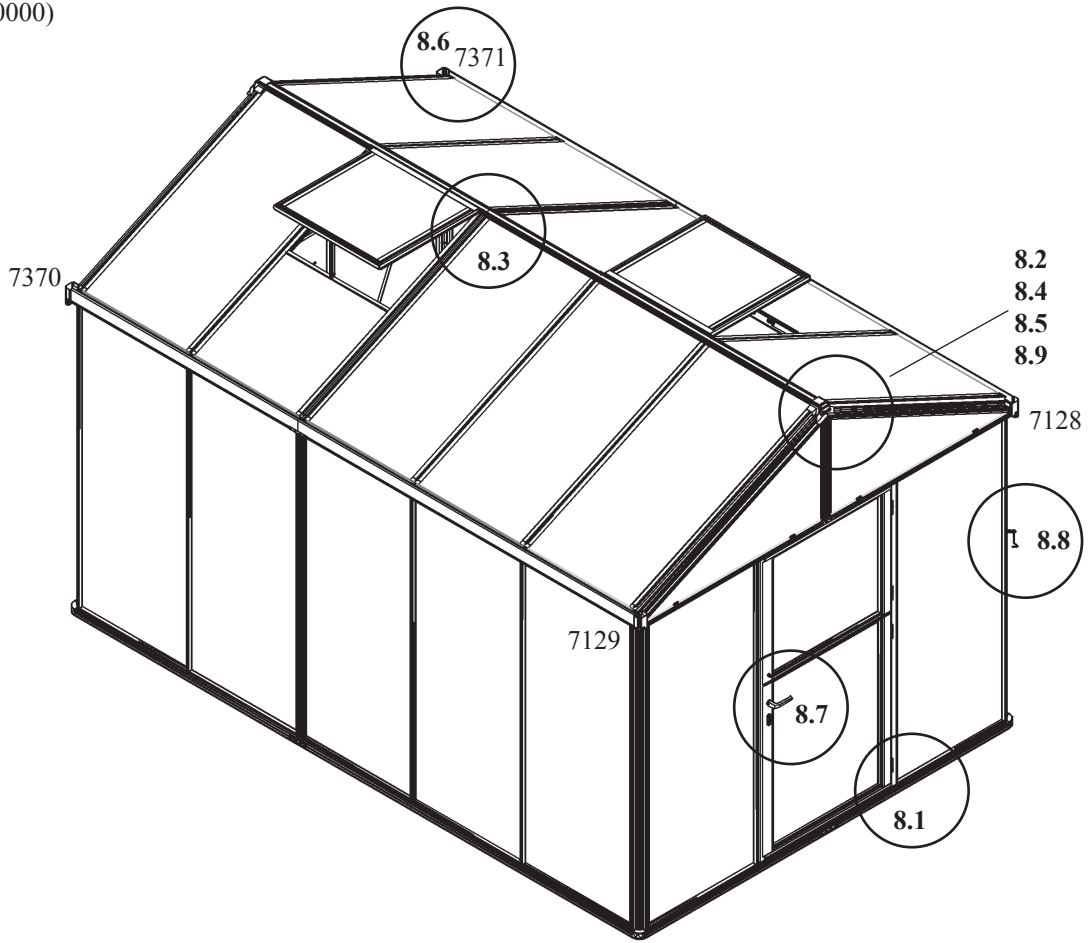

Model				
8100	10000	11900	13800	15700
7053				
1x	1x	1x	1x	1x
7088				
16x	16x	16x	16x	16x
7111				
1x	1x	1x	1x	1x
7112				
1x	1x	1x	1x	1x
7113				
1x	1x	1x	1x	1x
7128				
1x	1x	1x	1x	1x
7129				
1x	1x	1x	1x	1x
7266				
2x	2x	2x	2x	2x
7349				
4x	4x	6x	6x	6x
7369				
4x	4x	6x	6x	6x
7370				
1x	1x	1x	1x	1x
7371				
1x	1x	1x	1x	1x
7399				
1x	1x	1x	1x	1x

VM0009-Z2

FÆRDIGGØRELSE

BEMÆRK VENLIGST:

Kontroller, at drivhuset er i lod og vater og at alle bolte og møtrikker er monteret korrekt, at de har anslag og er spændte. Efter ca. 14 dage kontrolleres, om møtrikkerne har fast hold, ellers efterspændes uden at overspænde

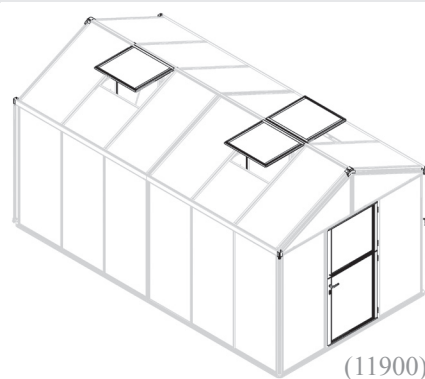

(11900)

Fastgør både den øverste og den nederste dørdel (samlet i trin 6a og 6b) til dørrammen 7045 ved hjælp af de selvskærende skruer 7088, se (8.1).

Skub ventilationsvinduerne på plads ved at lade disse glide ind i sporet på tagryggen, se (8.2). Fastgør vinduesstop 7369 ved at isætte selvborende skruer 7349 i de forborede huller på begge sider af tagvinduet (8.3), (8.4).

Monter tagrygafdækningen 7266 i begge ender af tagryggen med 2 selvskærende skruer 7088 som vist i (8.5).

Pres afløbsstudserne 7128, 7129, 7370 og 7371 på plads ind i tagrenderne 7213/7214 og 7215 i (8.6).

☝ Tip: Det kan være en hjælp forsigtigt at trække tagrendeprofilen lidt væk fra drivhuset, så åbningen til indpresning af studsene til nedløbsrøret bliver større.

Monter øsken 7111 på dørprofil 7018 i det forborede hul som vist i (8.7). Husk at montere afstandsbøsning 7112.

Monter bolt 7399 i sporet på hjørnestolpe 7236 og fastgør den løst ved hjælp af møtrik 7053. Juster højden på 7399/7053, så højden passer til øsken 7111 på dørprofil 7018. Spænd 7399 fast med 7053.

Monter dørkrog 7113 på bolt 7399, se (8.8).

Det anbefales at lægge en streng neutral silikone udvendigt ved tagrygsamlingen og ligeledes indvendigt tre steder i hver gavl, hvor tagryggen støder an mod gavlen, se (8.9). NB! Silikone indgår ikke i leverancen.



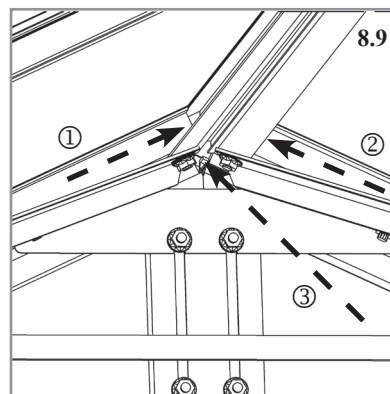
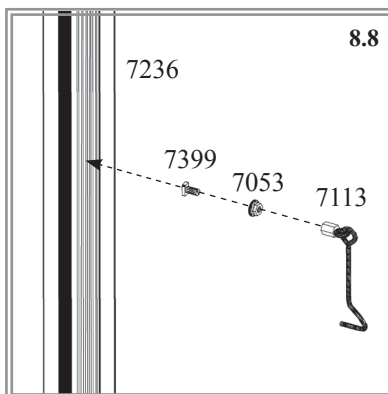
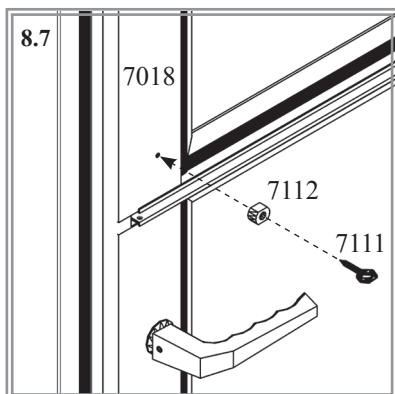
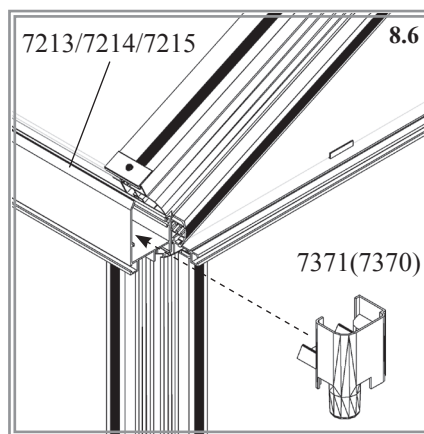
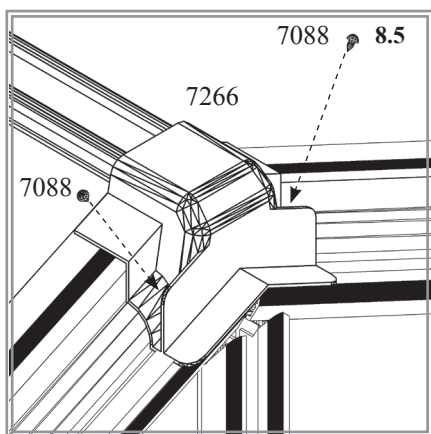





Den vedlagte selvklæbende identifikationsetiket anbringes indvendigt i drivhuset – f.eks. indvendig på døren eller lign. Oplysningerne på etiketten vil gøre det meget lettere for Dem at fremskaffe reservedele, såfremt dette skulle blive aktuelt.



Færdiggørelse

VM0009-Z2

Alle modeller

1002	2x	
1006	2x	
1402	2x	
1403	2x	
1405	2x	
1409	2x	
1412	2x	
1415	2x	

(11900)

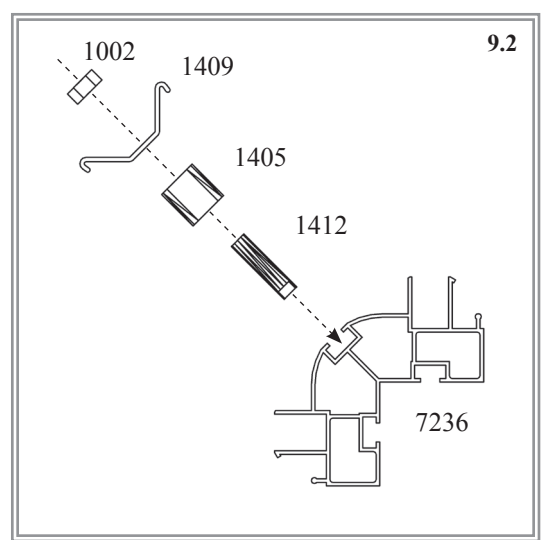
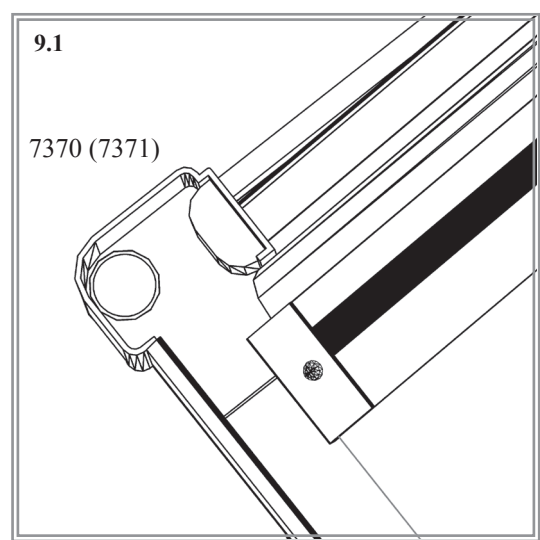
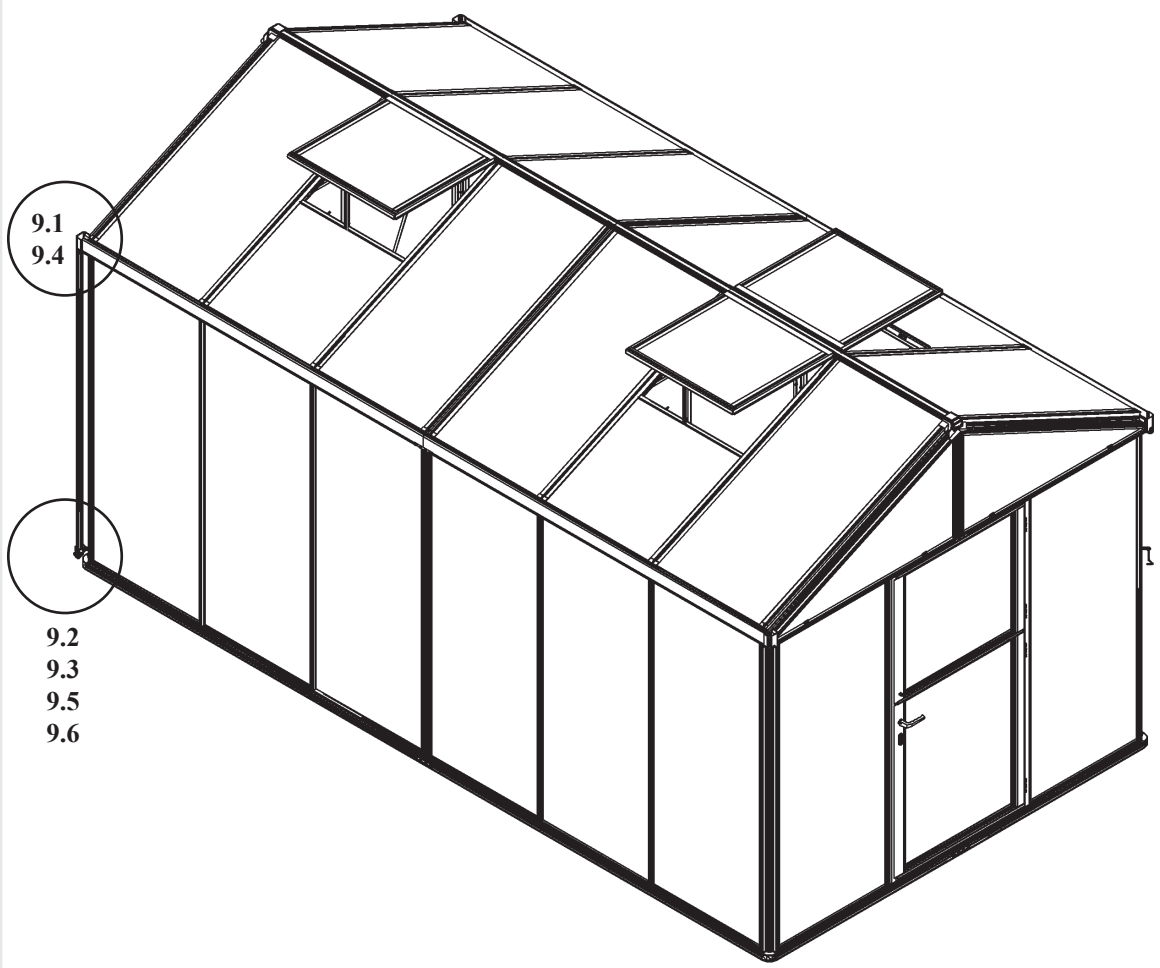

VM0009-Z2

NEDLØBSRØR

BEMÆRK VENLIGST:

Vi anbefaler brug af arbejdshandsker og beskyttelsesbriller.

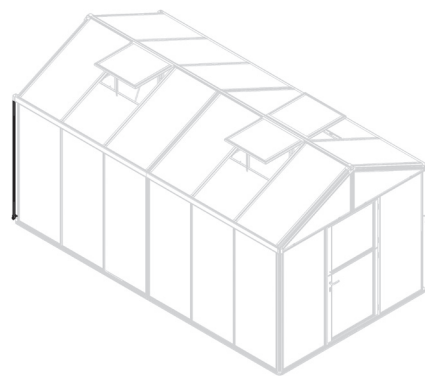

Indsæt en bolt med tilfilet hovede 1412 i bunden af boltsporet i hjørnestolpe 7236 og monter bøsning 1405 og beslag 1409 med møtrik 1002 på begge sider af drivhuset, se (9.2). Klem bøjning 1402 fast på nederste del af nedløbsrøret 1415, se (9.3), og klem derefter røret op omkring studsene til nedløbsrøret 7370 eller 7371, se (9.4). Klem beslag 1403 fast rundt om nedløbsrøret og pres derefter 1403 således at klembeslaget får greb i flangen på beslag 1409, se (9.5). Isæt skrue 1006 til fastholdelse af nedløbsrøret, se (9.6).

Vi ønsker Dem god arbejdslyst og håber, at De får rigtig mange gode stunder med og i Deres Vitavia drivhus.

Med venlig hilsen
OPJ A/S

Nedløbsrør

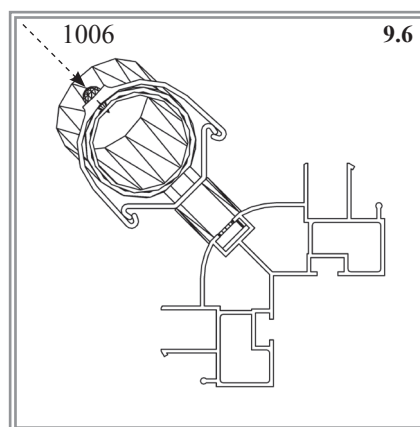
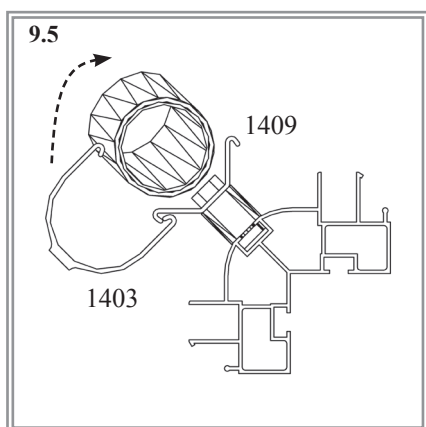
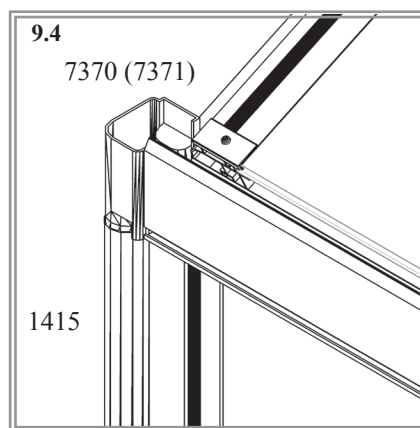
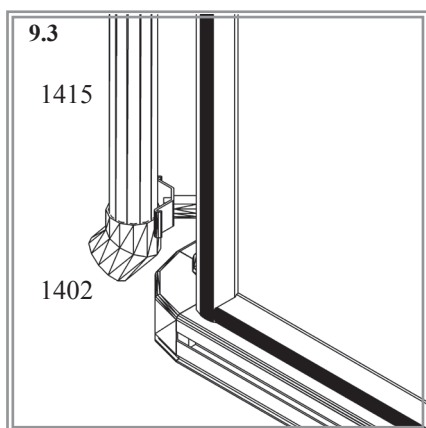

VM0009-Z2



E.P.H. Schmidt u. Co. GmbH
Hoefkerstrasse 30
44149 Dortmund
Postfach 170163
44060 Dortmund
Deutschland
Tel.: +49 231 941655 0
Fax: +49 231 941655 99
www.eph-schmidt.de
verkauf@eph-schmidt.de

OPJ A/S
Volderslevvej 36 A
5260 Odense S
Danmark
Tel.: +45 66 15 10 30
Fax: +45 66 15 00 84
www.opj.dk
opj@opj.dk